

MSD ADDENDUM

GM HEI ROTOR BUSHING INFORMATION

IMPORTANT: If you are installing an MSD Ignition to a GM HEI (Internal Coil) Distributor, read the following notice.

The Rotor Bushings used in GM HEI Distributors are made from high resistance carbon to help suppress radio frequency interference. However, when the increased voltage and spark energy of an MSD Ignition Control is added, this high resistance may build up excessive heat which may damage the cap or rotor.

This cap is supplied with a stock GM rotor bushing as well as an MSD Low Resistance Bushing, PN 8412, which only has 1 - 3 ohms. The Low Resistance Bushing allows the secondary voltage to be transferred from the cap to the rotor without excessive heat build up. The stock bushing is black with a bronze tip while the Low Resistance Bushing is solid bronze.

Stock HEI or a Performance Coil: It is recommended to use the Stock Rotor Bushing in stock applications. The higher resistance reduces the chance of excessive Electro Magnetic Interference, or radio noise. If you have only added a performance coil, use this Bushing as well.

MSD 6 Series Ignitions: GM used a variety of Rotor Bushings with a large variance in resistance and in most cases with a 6 Series Ignition, the Low Resistance Bushing is not required. In applications where the engine will be running at high rpm for long amounts of time, it is recommended to use. If you experience any problems within your cap and rotor, install the PN 8412.

MSD 7 Series Ignitions: The Low Resistance Bushing is required.

Note: The MSD Pro-Billet HEI Distributor, PN 8365, is supplied with the Low Resistance Bushing.

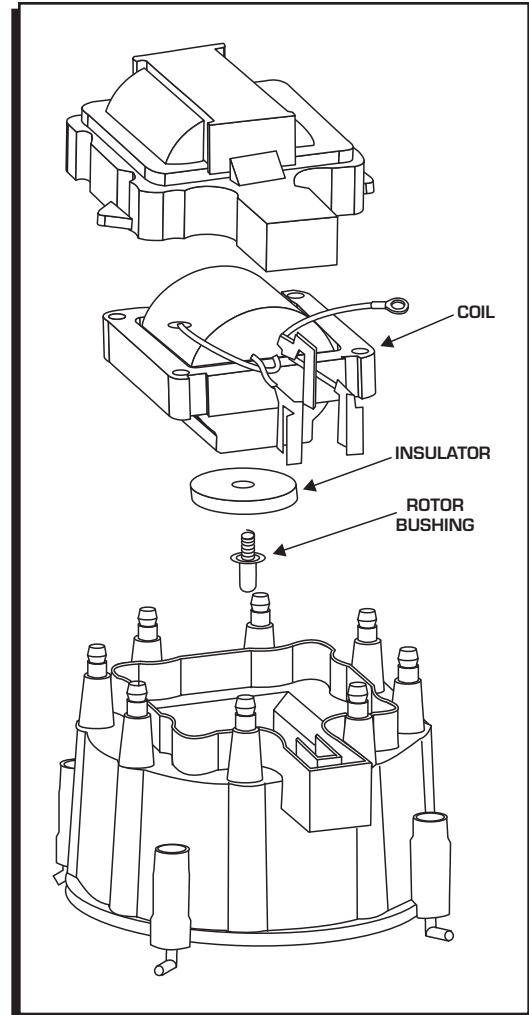

Technical Support
1-866-464-6553

FRM33467
Revision Date: 03/23