



INSTALLATION INSTRUCTIONS

DynaForce™ 120 and 160 Amp Alternators

120 Amp - PN 5321MSD, PN 5322
160 Amp - PN 5361, PN 5362

ONLINE PRODUCT REGISTRATION: Register your MSD product online. Registering your product will help if there is ever a warranty issue with your product and helps the MSD R&D team create new products that you ask for! Go to www.msperformance.com/registration.

Parts Included:
 1 – Alternator 1 – Single Groove Pulley, PN 5311 1 – Top Mounting Bolt

WARNING: During installation, disconnect the battery cables. When disconnecting the battery always remove the Negative cable first and install it last.

CHARGE WIRE

The MSD DynaForce Alternator is designed as a self exciting, or one-wire alternator. That means there is only one connection necessary, from the battery positive terminal to the charge terminal on the side of the housing. The gauge wire that is used for this charge wire varies depending on the battery location and the current your vehicle will require. The chart in Figure 1 provides the gauge recommended base on current demands and the length of the charge wire. Also, be sure to use quality terminals and connections. Using too small of a gauge wire can result in damage to the alternator and may void your warranty.

AMPS	Recommended Charging Cable Gauge Size/Length							
	Up to 4'	4'-7'	7'-10'	10'-13'	13'-16'	16'-19'	19'-22'	22'-28'
105 - 125	6	6	4	4	2	2	2	0
125 - 150	6	6	4	2	2	2	2	0
150 - 175	4	4	4	2	2	0	0	0
175 - 200	4	4	2	2	0	0	0	0

Figure 1 Charge Wire Recommendation Chart.

The DynaForce Alternators do not require the external regulator. It can be completely removed from the vehicle, or left in place with the wiring disconnected from the regulator. If not, the indicator lamp in the dash will remain on. Also note that this indicator lamp will no longer be operative. If operation of the indicator is desired, see page 4.

PULLEY SIZE AND RATIO

The MSD DynaForce 120 and 160 Amp Alternators are supplied with a single groove V-belt pulley. Also, if you require a special pulley, the shaft of the alternator is a common 17mm shaft that will accept some other pulley systems.

The pulley supplied has a diameter of 2.80" and a 3:1 pulley ratio is recommended for the street. (As an example, when your engine is at 1,500 rpm, the alternator should be at 4,500 rpm.) The DynaForce Street Alternators can handle up to 18,000 rpm maximum. They are most efficient when operating at about 2,400 alternator rpm and function best between 2,400 and 7,500 alternator rpm.

$$\frac{\text{Crankshaft Pulley Diameter}}{\text{Alternator Pulley Diameter}} = \text{Pulley Ratio}$$

EXAMPLE:

$$\frac{8.75''}{2.8''} = 3.125 \text{ Pulley Ratio}$$

$$\text{Pulley Ratio} \times \text{Engine RPM} = \text{Alternator RPM}$$

EXAMPLE:

$$3.1 \times 800 = 2480 \text{ Alternator RPM}$$

Keep in mind that underdrive crankshaft pulleys can affect the output of your MSD alternator at idle and lower rpm ranges. Therefore, underdrive pulleys are not recommended for street use.

INSTALLATION

The DynaForce Alternators listed at the top of these instructions are designed for use in applications that require straight mounts from top to bottom. Notice that the two mounting tabs are 180° apart. This is a common configuration for GM vehicles used from the mid 1960's through the mid 1980's. Check to confirm that you have the proper mount for your application before disassembly (Figure 2).

Mount the DynaForce using the factory hardware. Do not tighten the bolts entirely at this time. Once mounted, it is important to check the alignment of the pulleys. Place a straight edge on the water pump or crank pulley to the alternator pulley. If they are not

aligned, the alternator may require shimming. Also, note that some aftermarket brackets only have one solid mounting point such as systems that incorporate a turnbuckle or heim joint for tension adjustments. MSD recommends a secondary support to dampen vibration.

Note: If you are using anodized or powder coated brackets, it is recommended to connect a ground wire from the alternator housing to the engine block.

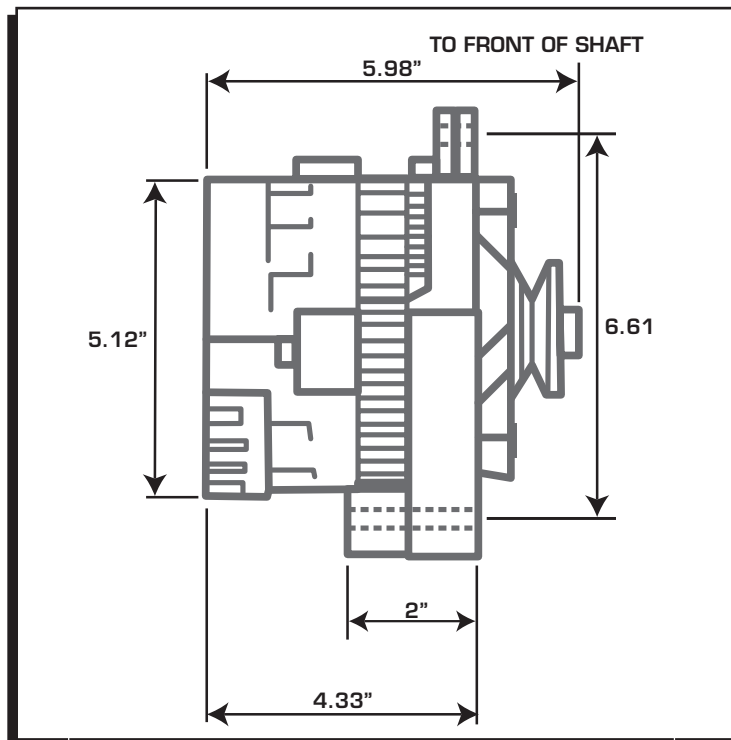

Figure 2 Alternator Dimensions.

Once the charge wire gauge is selected (see Figure 1), route the wire from the battery positive terminal to the alternator charge stud. Make sure to route the wire away from moving components and high heat sources. Install ring lug terminals to the ends of the wire and connect it to the battery positive terminal and the charge post.

BELT TENSION

Once aligned properly, install the belt and tighten the alternator in place. To check the belt tension, install a 15/16" socket and 3/8" ratchet wrench to the pulley nut of the alternator. Try to turn the nut clockwise as shown in Figure 3. The pulley should not turn, or just barely move with the other pulleys turning.

Note: Pulley discolorization or excessive belt dust are signs of improper tension.



Figure 3 Checking Belt Tension.

PRE-START CHECK LIST

- Be sure the battery is good and fully charged. A low battery can damage the alternator. Remember that alternators are made to maintain batteries, not to charge a weak or dead battery.
- Review the instructions and check the connection between the battery positive terminal and the charge terminal of the DynaForce Alternator.
- Reconnect the battery ground wire.
- Start the engine. Rev the engine to over 1,200 to excite the alternator so it starts charging.

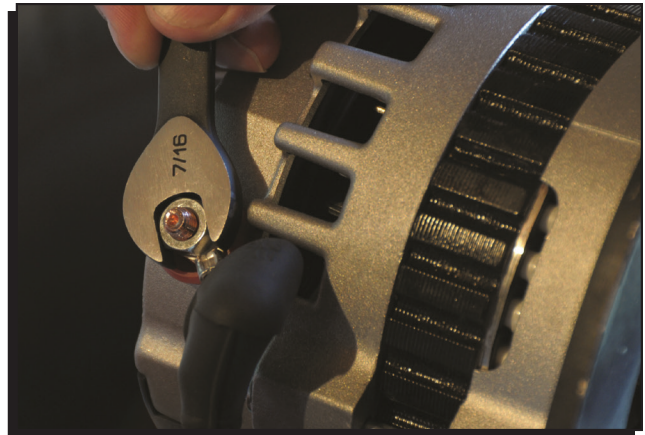

Figure 4 Installing the Charge Wire.

SYSTEM CHECKS

Once the alternator is installed and running, there are a few tests you can perform to ensure correct operation. For these checks you will need a digital volt meter.

With the engine running, rev the engine once to over 1,200 rpm. This ‘wakes up’ the alternator for it to begin charging as needed. Use a digital volt meter set to DC voltage, check the voltage across the battery terminals. Voltage should be from 13 – 14.5 volts. Next, check the voltage at the output terminal of the alternator to engine ground. Compare this value to that from the battery terminals. There should not be more than a .40 volt drop between the two measurements. If there is, check for poor connections or replace the charge wire with a larger diameter wire (See Figure 1).

If you are not seeing proper charging values, it is recommended to run a ground wire from the alternator housing to the engine block. Powder coated and anodized brackets do not provide a good ground path. Also confirm there’s a proper engine ground to the battery negative terminal.

⚠ CAUTION: Never disconnect the battery when the engine is running. Damage to the alternator will occur.

MSD INSTALLATION INSTRUCTIONS

CHARGE LAMP CONNECTION

In some applications the MSD DynaForce Alternator may be able to be wired to the factory charge indicator. In most cases, the factory indicator will turn on when the key is On with the engine off. The L terminal of the DynaForce will provide a ground for the indicator circuit when the alternator is NOT turning thereby completing the circuit and lighting the charge indicator. Once the alternator is spinning and excited, a positive voltage is activated on the L terminal. This removes the ground thereby turning the indicator off (Figure 5). This connector is located on the side of the housing.

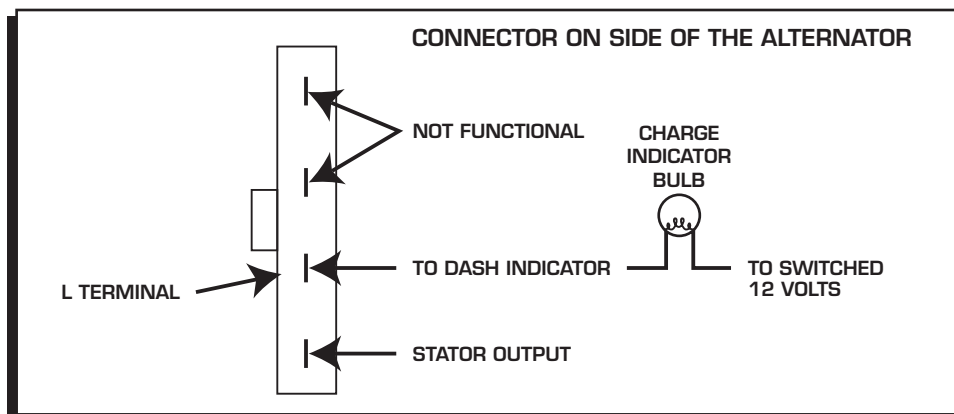

Figure 5 Connecting the OE Charge Lamp Indicator.

Service

In case of malfunction, this MSD component will be repaired free of charge according to the terms of the warranty. When returning MSD components for warranty service, **Proof of Purchase** must be supplied for verification. After the warranty period has expired, repair service is based on a minimum and maximum fee.

All returns must have a Return Material Authorization (RMA) number issued to them before being returned. To obtain an RMA number please contact MSD Customer Service at 1 (888) MSD-7859 or visit our website at www.msdpower.com/rma to automatically obtain a number and shipping information.

When returning the unit for repair, leave all wires at the length in which you have them installed. Be sure to include a detailed account of any problems experienced, and what components and accessories are installed on the vehicle. The repaired unit will be returned as soon as possible using Ground shipping methods (ground shipping is covered by warranty). For more information, call MSD at (915) 855-7123. MSD technicians are available from 7:00 a.m. to 5:00 p.m. Monday - Friday (mountain time).

Limited Warranty

MSD warrants this product to be free from defects in material and workmanship under its intended normal use*, when properly installed and purchased from an authorized MSD dealer, for a period of one year from the date of the original purchase. This warranty is void for any products purchased through auction websites. If found to be defective as mentioned above, it will be repaired or replaced at the option of MSD. Any item that is covered under this warranty will be returned free of charge using Ground shipping methods.

This shall constitute the sole remedy of the purchaser and the sole liability of MSD. To the extent permitted by law, the foregoing is exclusive and in lieu of all other warranties or representation whether expressed or implied, including any implied warranty of merchantability or fitness. In no event shall MSD or its suppliers be liable for special or consequential damages.

*Intended normal use means that this item is being used as was originally intended and for the original application as sold by MSD. Any modifications to this item or if it is used on an application other than what MSD markets the product, the warranty will be void. It is the sole responsibility of the customer to determine that this item will work for the application they are intending. MSD will accept no liability for custom applications.