



INSTALLATION INSTRUCTIONS FOR  
**MEGASHIFTER™**  
**UNIVERSAL SHIFTER**  
**Part No. 80690**

for the automatic transmissions listed below



MANUFACTURER	TRANSMISSION
Chrysler (1966+) and AMC (1972+)	A727 / A518 and A904 / A500
Ford	C4 / C5 and C6
GM (Turbo-Hydramatic)	TH200, TH250, TH350, TH400, 200-4R and 700R4 / 4L60
GM (electronic, <b>without</b> PRNDL switch)	4L60E, 4L65E, 4L70E, 4L75E, 4L80E and 4L85E

The shifter can also be used with the following transmissions, **with the applicable B&M install kits** (sold separately).

**NOTE:** Additional instructions for these transmissions are included with their respective install kits.

**INTRODUCTION**

The MegaShifter™ is by far B&M’s most popular shifter design, for both its form and its function. With its smooth, ratchet-shifting action, you won’t miss a shift. It is compatible with both standard- and reverse-pattern valve bodies. And its “one-hand” reverse lockout trigger meets NHRA and IHRA safety requirements.

**Before starting, take the time to read and understand these instructions.**

**Also, use the parts list to verify your kit’s contents.** In the unlikely event that any parts are missing, please contact B&M Technical Support for replacements.

**NOTE:** Some hardware bags are shared by similar B&M shifters. While your bag may include extra items that are used on other shifters, the parts list below shows all the parts required for this shifter.

**REQUIRED SUPPLIES**

- Medium strength thread-locking fluid (Permatex Blue or equivalent)

**APPLICABLE TRANSMISSIONS**

This shifter kit **includes all cable brackets and selector levers** required for use with the following automatic transmissions:

MANUFACTURER	TRANSMISSION	INSTALL KIT
Ford	AOD	40496
Ford	AODE and 4R70W	40504
Ford	E40D and 4R100	40505
GM (electronic, <b>with</b> PRNDL switch)	4L60E, 4L65E, 4L70E, 4L75E, 4L80E and 4L85E	70499

**NOTES**

- Installation requires better-than-average mechanical knowledge and skills. If this job is beyond your abilities, seek the services of a qualified technician.
- The shifter mechanism is precision-assembled at our factory. **Any modification or disassembly of the shifter will void its warranty, and can cause it to malfunction.** Disassemble items **only** where specified in the instructions.
- Installation of this shifter may require modification or complete removal of your vehicle’s console, depending on the space available in your vehicle.
- If you do not understand any part of these instructions, please call **B&M Technical Support** at **(866) 464-6553** for assistance.

- The shifter cable in this kit is 5 feet long. Different length shifter cables are available separately from B&M, if required.
- The shifter-transmission positions mentioned throughout these instructions apply to standard (forward) pattern transmissions (P-R-N-D-2-1). Transmissions with reverse-pattern manual valve bodies (P-R-N-1-2-D) will alter your shifter-transmission positions accordingly. **An indicator window for reverse-pattern 3-speed transmissions is available from B&M.**

## PARTS LIST

DESCRIPTION	QTY
JAM NUT, 1/2-20	1
T-HANDLE	1
SHIFTER ASSEMBLY,	1
WASHER, FLAT 1/4"	12
BOLT, 1/4-20 x 1-1/4"	4
CABLE, SHIFTER 5'	1
E-CLIP, 1/4" I.D.	1
BOLT, 1/4-20 x 1/2"	1
NUT, HEX 1/4-20	6
MICRO-SWITCH	2
SCREW, 4-40 x 1-1/4"	2
WASHER, SPLIT LOCK #4	2
NUT, HEX 4-40	2
WASHER, SPLIT LOCK 1/4"	5
SELECTOR LEVER, CHRYSLER / AMC	1
CABLE BRACKET, CHRYSLER / AMC	1
SELECTOR LEVER, FORD C4 / C5 and C6	1
CABLE BRACKET, FORD C4 / C5	1
CABLE BRACKET, FORD C6	1
SELECTOR LEVER, GM TH & ELECTRONIC	1
CABLE BRKT, GM TH & ELECTRONIC (NO PRNDL SWITCH)	1
BOLT, 1/4-20 x 1-1/2"	1
BOLT, 5/16-18 x 1"	2
BOLT, M8-1.25 x 25 (FOR GM & FORD 4-SPEEDS)	2
WASHER, FLAT 5/16"	2
SPACER, 7/16" I.D. x 1/4" L	2
SWIVEL, CABLE	1
JAM NUT, 10-32 (COMES INSTALLED ON CABLE END)	1
PIN, COTTER 1/16" x 1"	1
WIRE TERMINAL, FEMALE, 1/4", BLUE, 16-14 AWG	4
TOWER, SHIFTER	1
COVER ASSEMBLY	1
INDICATOR WINDOW, 4-SPEED	1
E-CLIP, 1/8" I.D.	1
SCREW, SHEET METAL, #6 x 1/4"	2
WASHER, #6	2
LIGHT BULB, INDICATOR	1
SCREW, PHILLIPS FLAT HEAD, 10-32 x 1/2"	2
SCREW, PHILLIPS PAN, TAPPING, 10-24 x 3/4"	4
BOOT, SHIFTER	1

## SAFETY WARNINGS

- **WORK SAFELY!** For maximum safety, perform this installation on a clean, level surface, with the engine turned off. Chock the wheels to prevent vehicle movement. To avoid bodily injury or vehicle damage, do not begin work until you are confident that the vehicle is safely secured and will not move.
- **AVOID SERIOUS INJURY OR DEATH BY CRUSHING!** If you have to raise the vehicle to work under it, securely support it on a lift or jack stands. **NEVER work under a vehicle that is supported only by jacks!**
- **WARNING: This B&M performance shifter uses a cable to shift the transmission only; it is NOT intended or designed to operate a locking steering column! If your vehicle has a locking steering column, it must either be a) MODIFIED, to allow the steering column to lock when the key is removed (modification described later); or b) DISABLED, to prevent the steering column from locking if the ignition switch is turned to LOCK while driving (not described in these instructions).** If you are not comfortable performing this work, or if you don't understand this warning, seek the services of a qualified technician for the safe installation of this shifter.

## INSTALLATION

### 1. Remove the stock shift linkage.

**Column Shifters:** Remove all rods, levers or cables from the column and the transmission. Place the column shift lever in the PARK position. Remove the pin holding the shift lever in the column and remove the lever assembly. If your vehicle is equipped with a locking steering column, secure the column lock lever in the full up position. **(See WARNING re. locking steering columns, above.)**

**Console Shifters:** Remove the shifter mechanism from the console. Disconnect the rod or the cable from the transmission. Remove the cable bracket if equipped. If there is a cable or linkage from the console shifter or transmission to the steering column lock, it must be secured in the PARK position as described above.

**Switch Wires:** While removing the stock shift linkage, look for neutral safety and / or backup light switches and wiring. (These mechanisms vary on different vehicles. **See the installation section for your vehicle for details.**) Label any such wires to simplify installation.

### 2. Temporarily thread the 1/2-20 jam nut and T-handle onto the shifter lever.

**CAUTION: Avoid cross-threading!** The T-handle should spin freely onto the stick with no resistance. **If you start to feel any resistance, STOP,** remove the handle, align the threads properly, and try again.

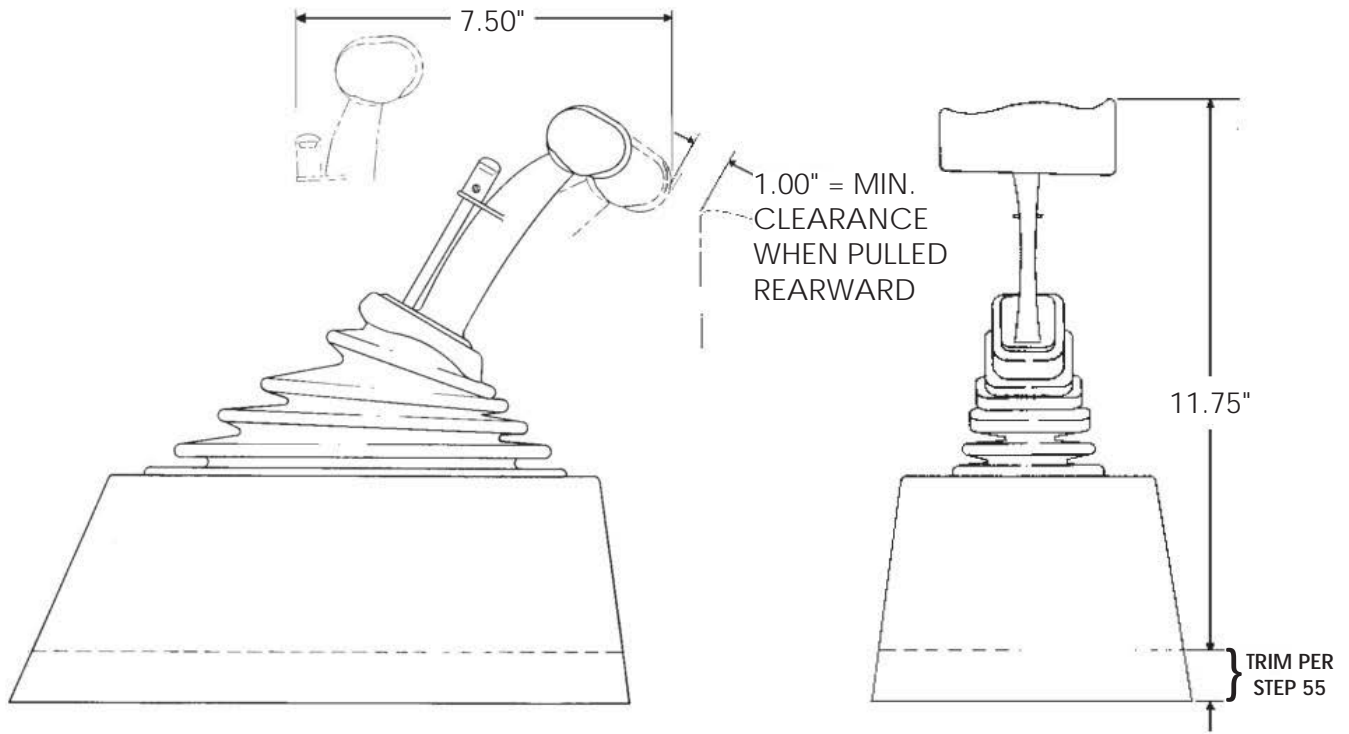

3. **Locate the B&M shifter in your vehicle.** Pull the carpet (if any) away from the floorboard where the shifter will be mounted. If the vehicle has a bench seat, move it to the full forward position.

**Note the shifter dimensions above. When the T-handle is pulled rearward, there must be at least 1" clearance between the handle and the seat when the seat is in the full forward position.** Make sure the T-handle will clear the dash and seat when it is pushed forward and rearward. When you are satisfied with the position of the shifter, mark the location of its four mount holes on the floor.

4. **Drill the mount holes.** Drill four 9/32" mount holes through the floor. Put the shifter in place. Shim it to level (if necessary) using the twelve 1/4" flat washers between the shifter and the floor, and temporarily hold it in place with the four 1/4-20 x 1-1/4" bolts.

5. **Mark and drill the cable hole.** Mark the center for the shifter cable hole 1-1/2" forward of the front edge of the shifter base (see Step 8 photo). Drill or cut a hole that will provide at least 3/16" clearance around the cable.

**NOTE:** If your vehicle's floor is too thin to properly support the shifter mechanism when bolted to it, fabricate a sheet metal stiffener to reinforce it.

6. **Return the carpet to its original position (but do not secure it yet).** Cut holes in the carpet for the shifter mount holes, and cut a suitable slit for the cable. **(Do not use a drill bit to make the holes in the carpet.)**

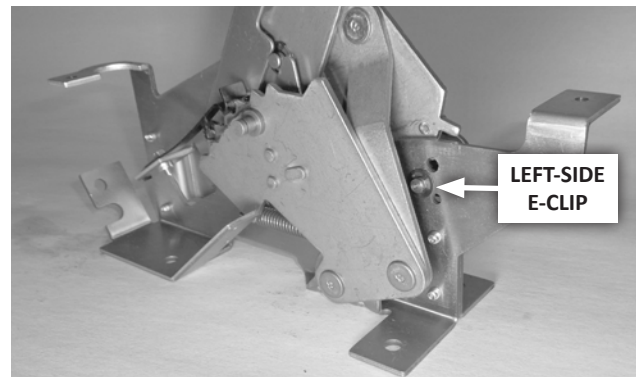

7. **Configure the speed limiter pin for your application** as shown below. (To remove the pin, remove the left-side e-clip, then push the pin out the right side.)

TRANSMISSION	SPEED LIMITER PIN
All Chrysler / AMC & Ford*	Leave installed
GM 3-speeds	Leave installed
GM 4-speeds	Remove

\* Selector levers on all Chrysler / AMC and Ford transmissions (whether 3- or 4-speed) have just 3 forward speed positions.

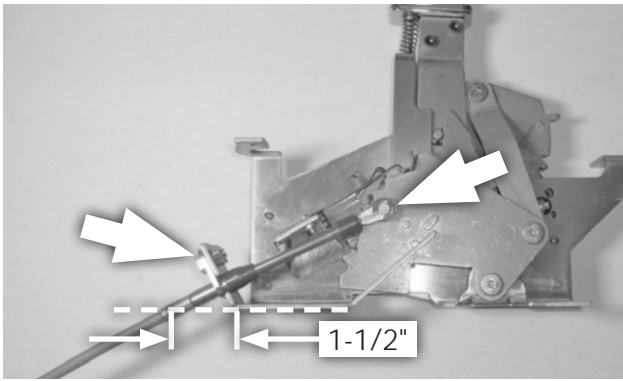

8. **Assemble the cable and shifter.** Secure the **cable eye** to the shifter pin with the **1/4" I.D. e-clip**. Then secure the cable's mount tab to the **outside** surface of the shifter base with the **1/4-20 x 1/2" bolt and nut** (apply **medium strength thread-locking fluid** to bolt).

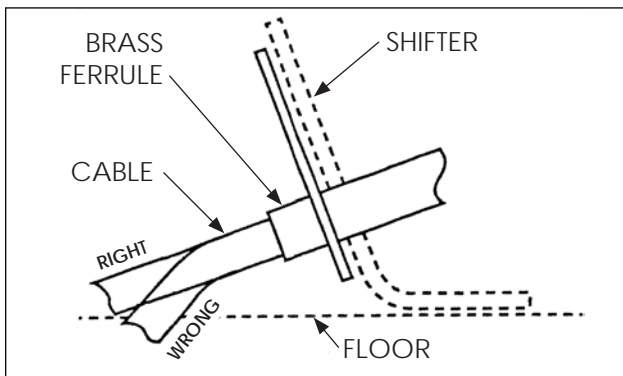

**CAUTION:** Do not kink the cable anywhere along its length, or it will lock up. The cable should be kept straight for at least 2" after it leaves the brass ferrule at each end.

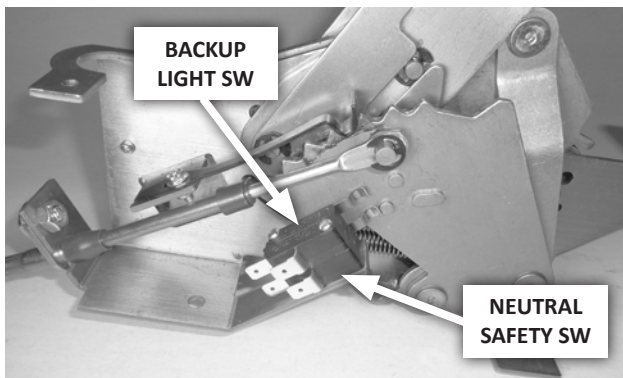

9. **Install the two switches on the shifter mechanism** as shown, using the two **#4-40 x 1-1/4" screws, lock washers and nuts**.

**NOTE:** Installation of the micro-switches is optional on 1969+ Chryslers and AMCs, as the stock neutral safety and backup light switches on the transmission will continue to function normally.

**CAUTION:** Tighten the fasteners only until the lock washers are squeezed flat. Over-tightening may crack the switch housings.

While tightening the fasteners, check placement of the switches to verify that:

- the **neutral safety (bottom) switch** closes in NEUTRAL and PARK only; and
- the **backup light (top) switch** closes in REVERSE only.

**NOTES**

- Refer to the "Operation" section to understand the positions of the shift lever.
- The switch mount holes normally allow the required adjustment for proper actuation. However, the switch arms may be carefully bent, if necessary.

10. **Install the shifter in the vehicle.** Slide the cable through the carpet and the hole in the floor, then bolt the shifter to the floor using the four **1/4-20 x 1-1/4" bolts, lock washers and nuts**, and using the twelve **1/4" flat washers** as leveling shims, if required. Do not bend the shifter mount tabs.

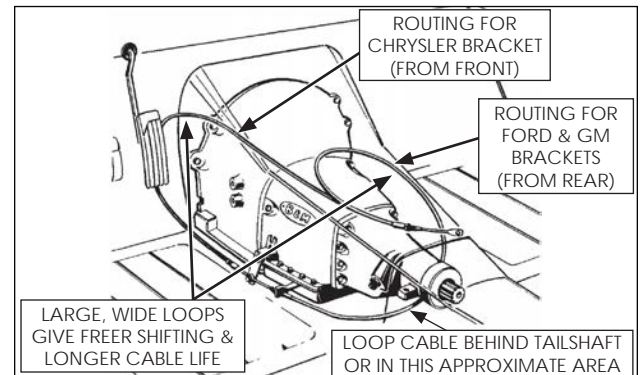

11. **Route the cable** approximately as shown, based on your application. **Avoid any sharp bends which may kink or otherwise damage the cable.** Seal the cable hole shut to keep exhaust fumes, water, etc. out of the passenger compartment. Use clamps and / or cable ties (customer supplied) to secure the cable housing in such a way as to prevent contact with the exhaust system, engine, or any moving parts.

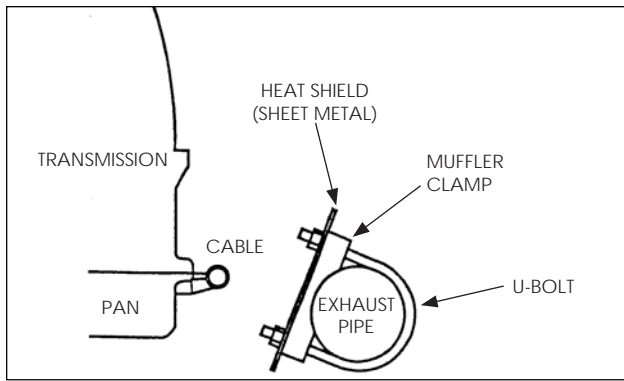

**CAUTION:** Heat will severely damage the shift cable, causing the housing to melt or become brittle. If the cable must be routed near exhaust system components, fabricate a heat shield. **Do not wrap the cable, as this retains heat.**

**NOTE:** The instruction photos show transmissions on a work bench, not installed in vehicles.

- For CHRYSLER / AMC applications, go to STEP 12.
- For FORD applications, go to STEP 25.
- For GM applications, go to STEP 40.

## CHRYSLER / AMC

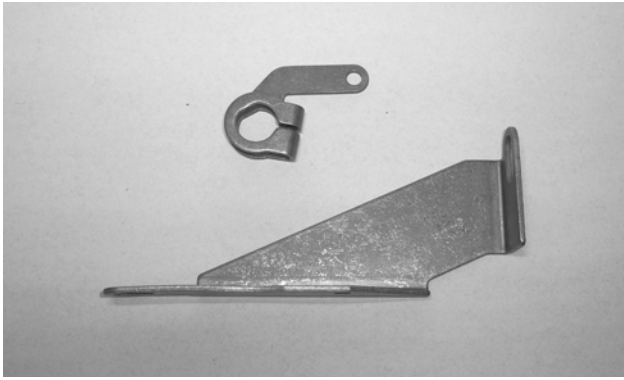

12. Get the Chrysler / AMC selector lever and cable bracket from the parts kit.

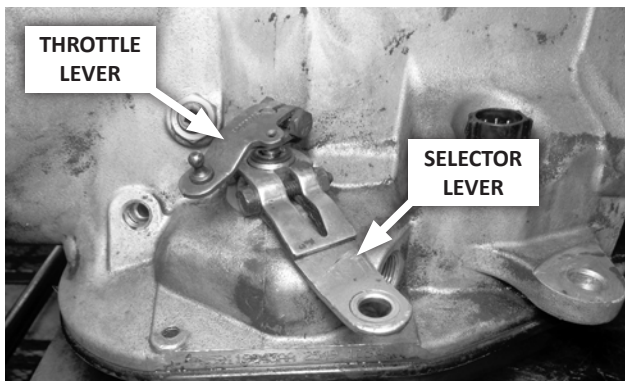

13. **Disconnect stock controls:** Loosen the throttle lever pinch bolt, remove the lever from its shaft, and carefully move the lever and linkage aside, allowing them to hang free. Remove and discard the stock selector lever and shift linkage.

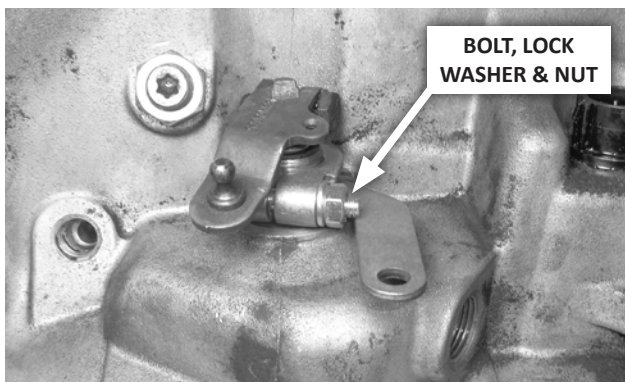

14. Install the B&M selector lever using the  $1/4-20 \times 1-1/2$ " bolt, and a  $1/4$ " lock washer and nut. Be sure the lever is not pushed down against the transmission case, which could cause binding. The lever should travel smoothly back and forth, with a positive "click" in each detent. Then reinstall the throttle lever and linkage, tighten its pinch bolt securely, and check for smooth operation.

**CAUTION:** To avoid stripping out your transmission's bolt holes, use the correct bracket bolts. This kit includes both SAE and metric bracket bolts. The metric bolts have finer threads. To choose the correct kit bolts for your transmission, compare them to the stock bolts you removed.

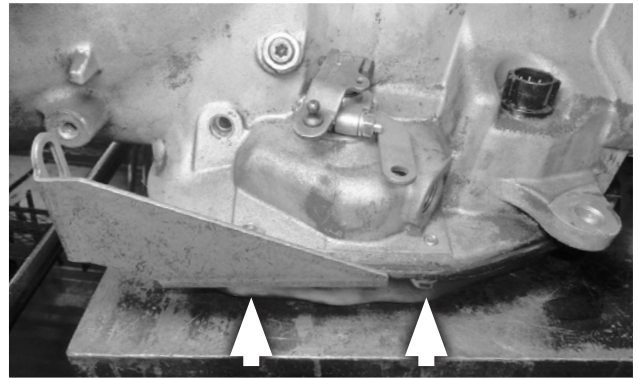

15. Install the cable bracket at the two pan bolt holes directly below the selector lever, using the two  $5/16-18 \times 1$ " bolts and flat washers. For stamped sheet-metal (stock) pans, use the two spacers between the pan and bracket. (Spacers are not used with cast aluminum pans.) Tighten the bolts to 12-13 ft-lbs torque.

**CAUTION:** Do not over-tighten the bolts, as this can damage the pan gasket.

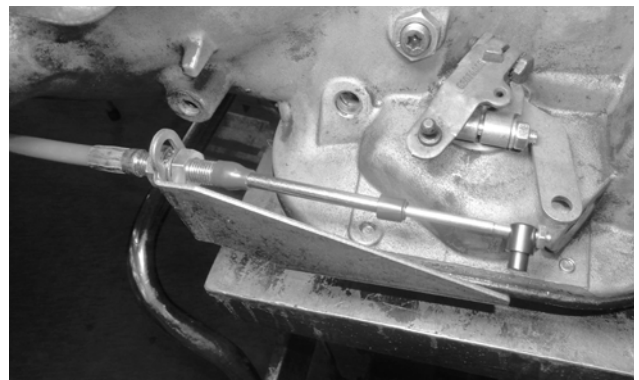

16. **Attach the shifter cable to the cable bracket:** First remove the small jam nut, both plastic dust boots, and one large nut and lock washer, from the cable. Then insert the cable through the cable bracket, reinstall the lock washer and nut (loosely, to allow room for adjustment), and reinstall the dust boots.

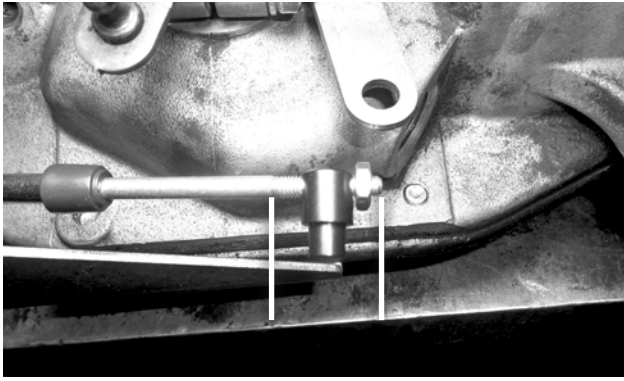

17. Thread the swivel onto the cable to about the middle of the threaded section, then reinstall (but do not yet tighten) the jam nut.

**NOTE:** Before proceeding, verify that the speed limiter pin is configured as described at **Step 7**.

18. Adjust the shifter cable as described below. (See "OPERATION" section to understand shifter positions.)

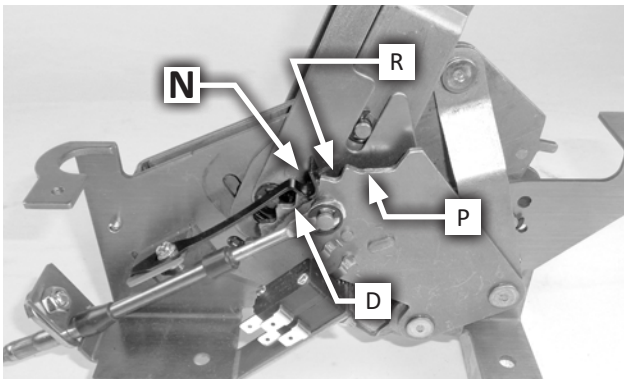
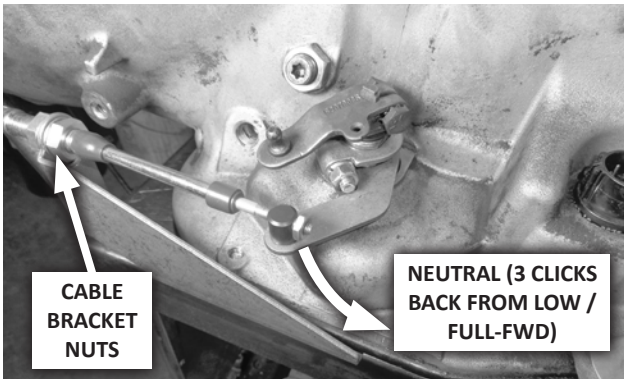

- A. Manually move the selector lever to the **NEUTRAL detent** (3 clicks back from LOW / full-forward), and move the shifter to the NEUTRAL position. Adjust the cable bracket nuts (and the swivel, if necessary) until the swivel slips freely in and out of the selector lever hole.
- B. Gradually tighten the cable nuts against the bracket while continuing to check the fit of the swivel in the

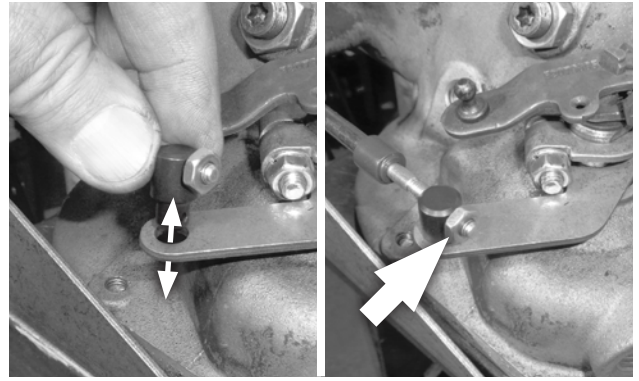

selector lever. Then with the swivel inserted in the selector lever, lightly snug the jam nut.

- C. With the swivel still in the selector lever, move the shifter to **DRIVE**, and check the fit of the swivel in the selector lever. The swivel should slip freely in and out of the hole. If not, adjust the cable bracket nuts (and swivel, if necessary) per **Step B**.
- D. Repeat for both **SECOND** and **REVERSE** gears.
- E. Move the shifter to **FIRST**, and check the fit of the swivel. There may be a slight drag in **FIRST**. This is normal; do not re-adjust the cable.

**CAUTION:** If you encounter restricted movement or any other problem during this process, **DO NOT FORCE THE SHIFTER**. Doing so may damage the cable, the shifter and / or the transmission. Simply return to **Step A** and re-check each step.

19. The cable is correctly adjusted when the swivel slips freely in and out of the lever in **REVERSE** through **SECOND** gears, and has a slight drag in **FIRST**. Verify that the two cable bracket nuts, and the cable swivel jam nut, are tight. Also verify that the vehicle does not roll with the transmission in **PARK**.

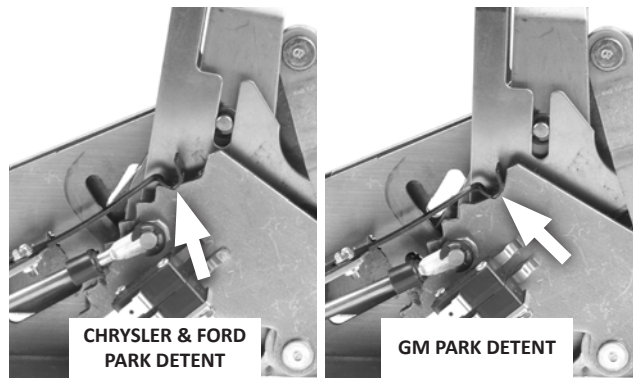

**CAUTION:** The shifter has two **PARK** positions — the first (lever full-forward) is for **GM** transmissions; and the second (one position back) is for **Chryslers and Fords**. To avoid stretching the shifter cable when shifting into **PARK**, NEVER force the shifter past the second (rear) **PARK** position (which corresponds to your transmission selector lever's **PARK** detent).

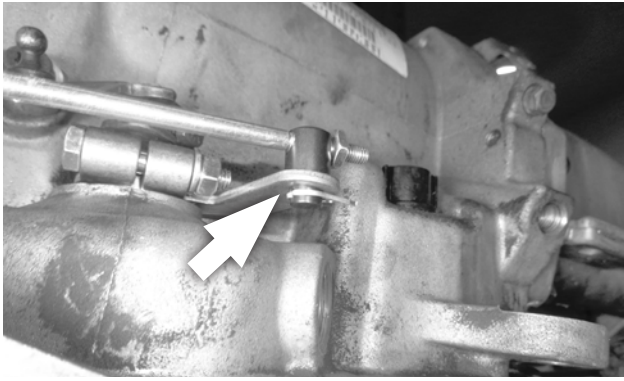

**20. Secure the swivel to the selector lever with the cotter pin.** Operate the shifter through all the gear positions, verifying that it operates correctly.

**21. Check the operation of the throttle linkage again.** The linkage must operate smoothly with no binding.

**CAUTION:** The throttle linkage must be connected and operating on all transmissions using automatic valve bodies, or transmission damage will result.

### NEUTRAL SAFETY AND BACKUP LIGHT SWITCHES

**1966-68 VEHICLES:** The stock neutral safety switch will continue to function normally. Therefore, only the backup light switch on the shifter will be used.

**22. Reroute the backup light switch wires:** Disconnect the battery ground cable. Then disconnect the wires from the stock backup light switch (located on either the steering column, or the console shifter). Route the wires to the B&M shifter.

**23. Wire the switch:** Strip 1/4" of insulation off the wires and crimp a **terminal** to each wire, **using an appropriate crimping tool.**

**CAUTION:** Failure to use an appropriate tool to crimp the terminals may result in defective, unreliable connections.

Tape or heat-shrink the terminal-wire connections for added protection of the crimps. Connect the backup light wires to the UPPER switch (see **Step 9**).

**24. Verify switch function:** Reconnect the battery ground cable. Check the backup light switch by verifying the backup light is on only when the shifter is in REVERSE. If required, adjust the backup light switch as described at **Step 9**.

**1969+ VEHICLES:** The stock neutral safety and backup light switches are located on the transmission, and will continue to function normally. Therefore, use of the B&M micro-switches is optional.

**Proceed to "Finish Installation," Step 55.**



FORD

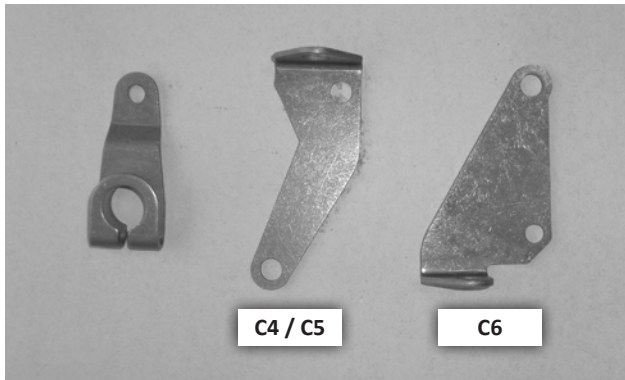

25. Get the Ford selector lever and appropriate cable bracket from the parts kit.

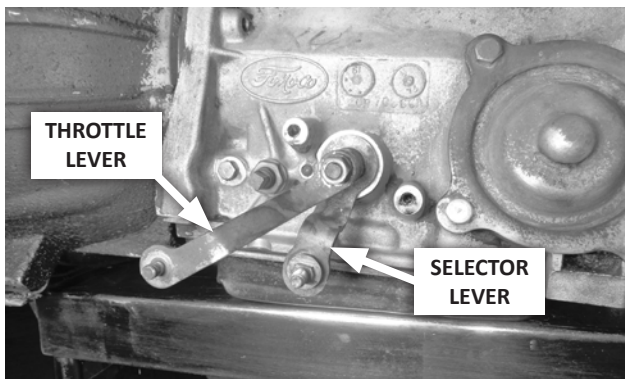

26. **Disconnect stock controls:** Remove and retain the nut and lock washer holding the throttle lever on its shaft. Carefully remove the throttle lever, and move it and its linkage aside, allowing them to hang free. Remove and discard the stock shift linkage.

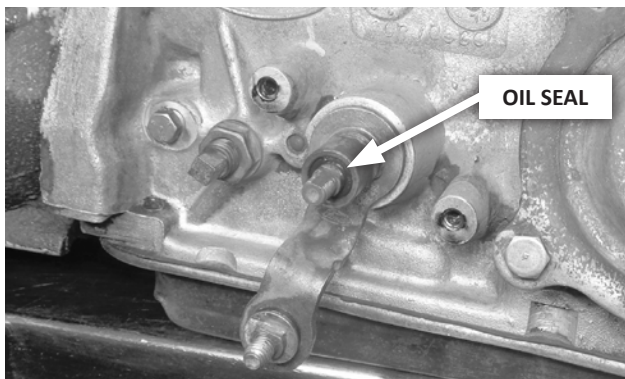

**CAUTION:** Ensure that the oil seal remains in place between the selector and throttle shafts. If the seal comes out, replace it before continuing.

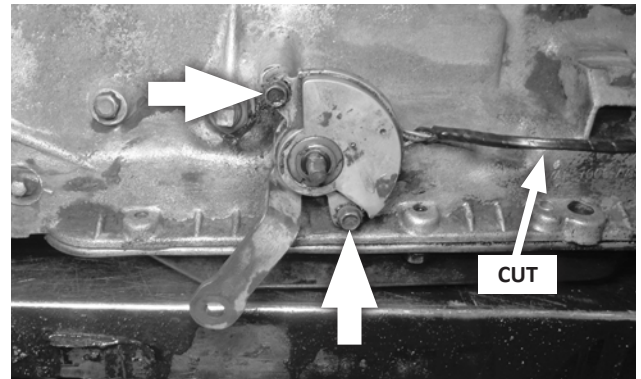

27. If your transmission is equipped with a neutral safety / backup light switch: Remove the two mount bolts and slide the switch off the selector shaft. Cut the wiring harness between the switch and its connector, and discard the switch. (The wires from the connector will be routed to the B&M switches later.)

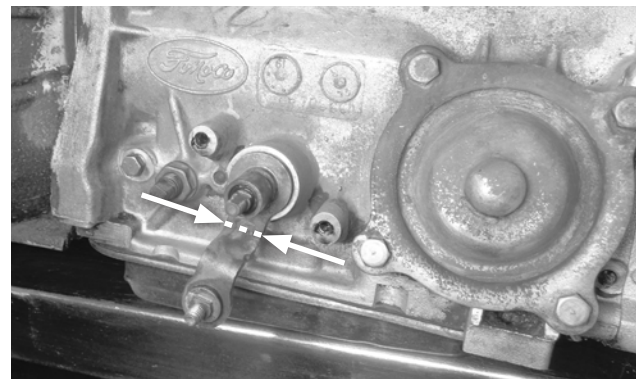

28. **Move the selector lever to NEUTRAL** (2 clicks back from PARK / full forward). If the selector lever points downward, cut it off at the inboard bend, to allow correct positioning of the B&M lever.

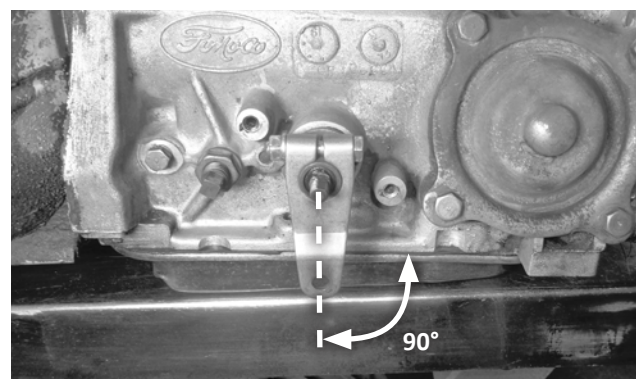

29. **Install the B&M selector lever using the 1/4-20 x 1-1/2" bolt, lock washer and nut.** (See NOTE on next page.) With the selector shaft still in NEUTRAL, align the selector lever perpendicular to the oil pan split-line, then tighten the fasteners.

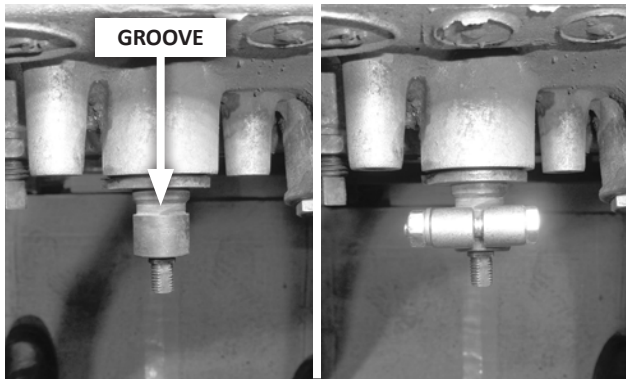

**NOTE:** If the selector shaft is grooved as shown, center the lever between the groove and the end of the shaft, so that the lever's inboard clamping surface does not land in the groove.

The lever should travel smoothly back and forth, with a positive "click" in each detent.

### 30. Install the cable bracket:

**CAUTION:** To avoid stripping out your transmission's bolt holes, use the correct bracket bolts. This kit includes both SAE and metric bracket bolts. The metric bolts have finer threads. To choose the correct kit bolts for your transmission, compare them to the stock bolts you removed.

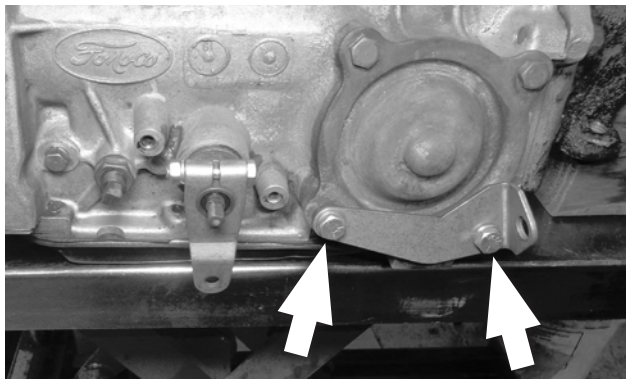

A. **C4 / C5 transmissions:** Install the **cable bracket** at the two lower servo cover bolt holes, using the two **5/16-18 x 1" bolts, flat washers and spacers**. Tighten the bolts to 12-13 ft-lbs torque.

**CAUTION:** Do not over-tighten the bolts, as this can distort the servo cover.

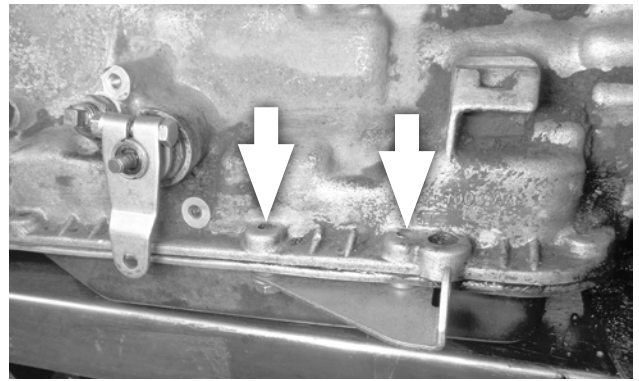

B. **C6 transmissions:** Install the **cable bracket** at the two left rear oil pan bolt holes, using the two **5/16-18 x 1" bolts and flat washers**. For stamped sheet-metal (stock) pans, use the two **spacers** between the pan and bracket. (Spacers are not used with cast aluminum pans.) Tighten the bolts to 12-13 ft-lbs torque.

**CAUTION:** Do not over-tighten the bolts, as this can damage the pan gasket.

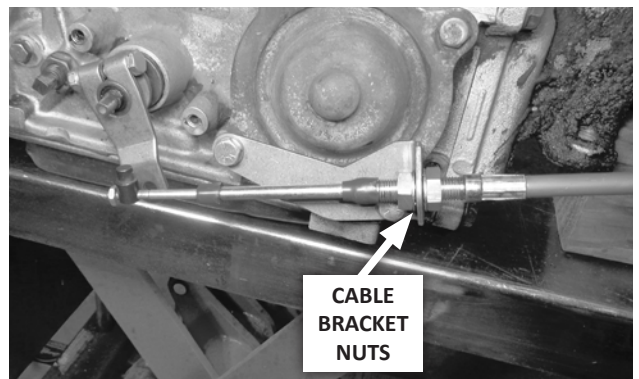

31. **Attach the shifter cable to the cable bracket:** First remove the small jam nut, both plastic dust boots, and one large nut and lock washer, from the cable. Then insert the cable through the cable bracket, reinstall the lock washer and nut (loosely, to allow room for adjustment), and reinstall the dust boots.

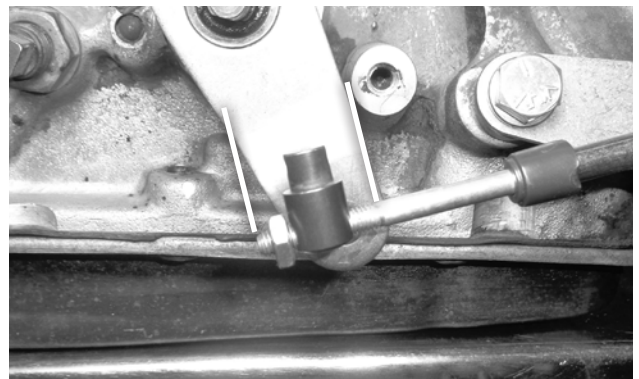

32. **Thread the swivel onto the cable** to about the middle of the threaded section, then reinstall (but do not yet tighten) the **jam nut**.

**NOTE:** Before proceeding, verify that the speed limiter pin is configured as described at **Step 7**.

**33. Adjust the shifter cable** as described below. (See “OPERATION” section to understand shifter positions.)

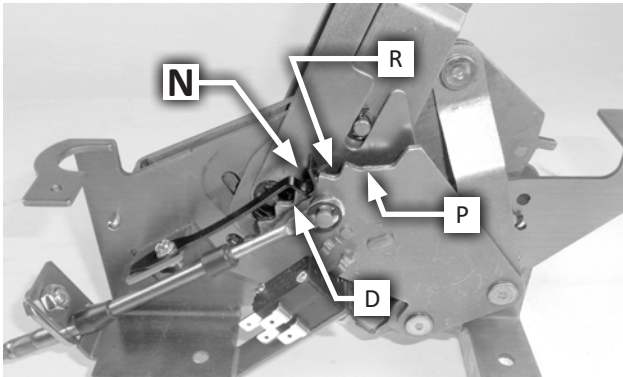

**A. With the selector lever still in NEUTRAL** (2 clicks from PARK), place the shifter in the NEUTRAL position, and adjust the cable bracket nuts (and swivel, if necessary) until the swivel slips freely in and out of the selector lever hole.

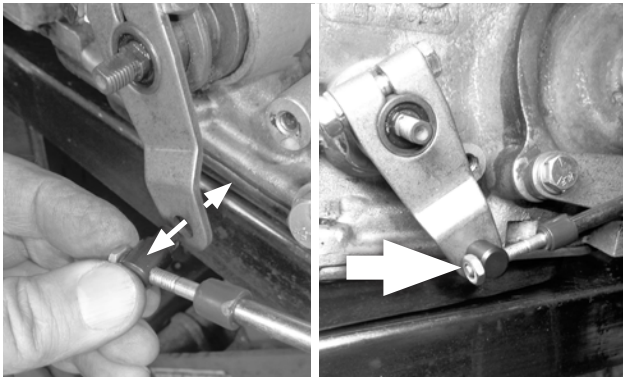

**B. Gradually tighten the cable nuts against the bracket** while continuing to check the fit of the swivel in the selector lever. Then with the swivel inserted in the selector lever, lightly snug the jam nut.

**C. With the swivel still in the selector lever, move the shifter to DRIVE**, and check the fit of the swivel in the selector lever. The swivel should slip freely in and out of the hole. If not, adjust the cable bracket nuts (and swivel, if necessary) per **Step B**.

**D. Repeat** for both SECOND and REVERSE gears.

**E. Move the shifter to FIRST**, and check the fit of the swivel. There may be a slight drag in FIRST. This is normal; do not re-adjust the cable.

**CAUTION: If you encounter restricted movement or any other problem during this process, DO NOT FORCE THE SHIFTER.** Doing so may damage the cable, the shifter and / or the transmission. Simply return to **Step A** and re-check each step.

**34. The cable is correctly adjusted** when the swivel slips freely in and out of the lever in REVERSE through SECOND gears, and has a slight drag in FIRST. Verify that the two cable bracket nuts, and the cable swivel jam nut, are tight. Also verify that the vehicle does not roll with the transmission in PARK.

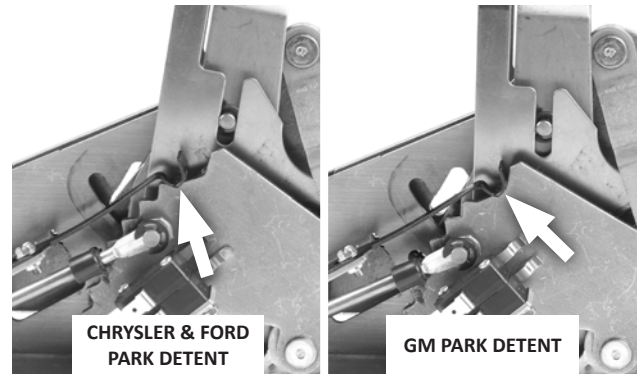

**CAUTION:** The shifter has two PARK positions — the first (lever full-forward) is for GM transmissions; and the second (one position back) is for Chryslers and Fords. To avoid stretching the shifter cable when shifting into PARK, NEVER force the shifter past the second (rear) PARK position (which corresponds to your transmission selector lever’s PARK detent).

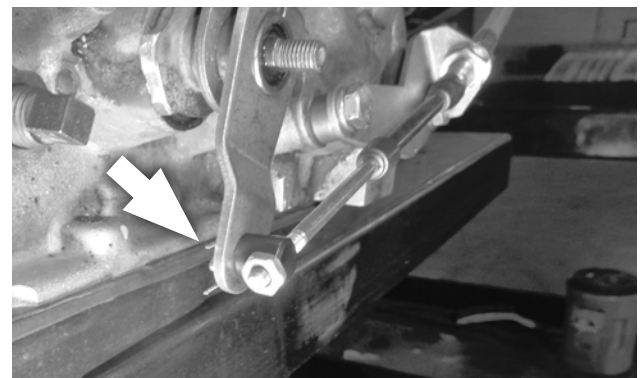

**35. Secure the swivel to the selector lever with the cotter pin.** Operate the shifter through all the gear positions, verifying that it operates correctly.

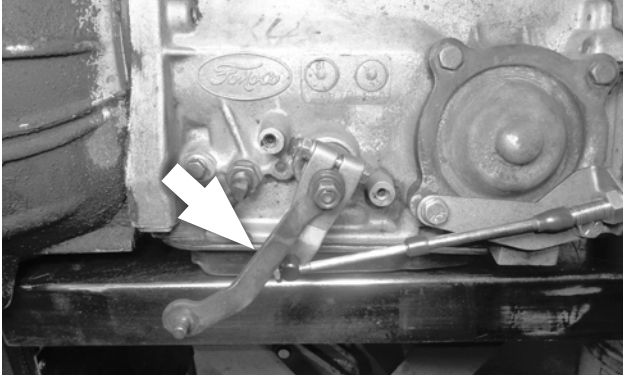

- 36. Reinstall the throttle lever, lock washer and nut** on the throttle shaft and tighten securely. The throttle lever must operate smoothly with no binding.

**CAUTION:** The throttle linkage must be connected and operating on all transmissions using automatic valve bodies, or transmission damage will result.

### NEUTRAL SAFETY AND BACKUP LIGHT SWITCHES

- 37. Reroute the switch wires:** Use an applicable electrical schematic to locate and identify the two neutral safety circuit wires (which prevent cranking unless the transmission is in NEUTRAL or PARK), and the two backup light wires. Disconnect the battery ground cable. Route both pairs of wires to the B&M shifter.

- 38. Wire the switches:** Strip 1/4" of insulation off the wires and crimp a **terminal** to each wire, **using an appropriate crimping tool**.

**CAUTION:** Failure to use an appropriate tool to crimp the terminals may result in defective, unreliable connections.

Tape or heat-shrink the terminal-wire connections. Connect the backup light wires to the UPPER switch, and connect the neutral safety wires to the LOWER switch (see **Step 9**).

- 39. Verify switch function:** Reconnect the battery ground cable, disconnect the coil wire and set the parking brake. Check the neutral safety switch by attempting to crank the engine in each shifter position. The starter must crank only when the shifter is in either PARK or NEUTRAL. Check backup light operation with the shifter in REVERSE. If required, adjust the switches as described at **Step 9**. After verifying correct switch operation, reconnect the coil wire.

Proceed to "Finish Installation," **Step 55**.

## GENERAL MOTORS

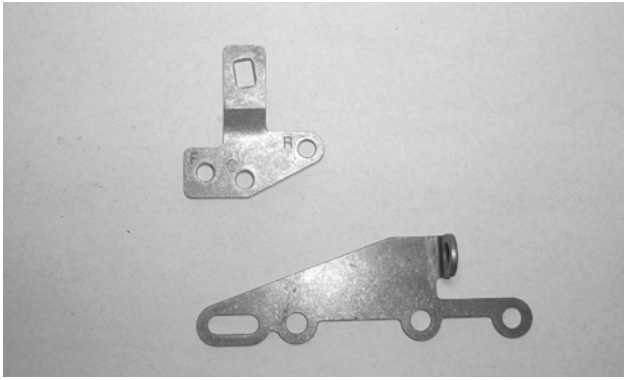

40. Get the GM selector lever and cable bracket from the parts kit.

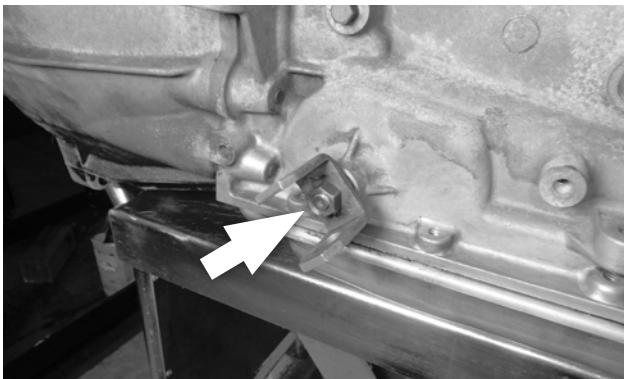

41. **Disconnect stock controls:** Remove and retain the selector lever nut. Remove and discard the selector lever and shift linkage.

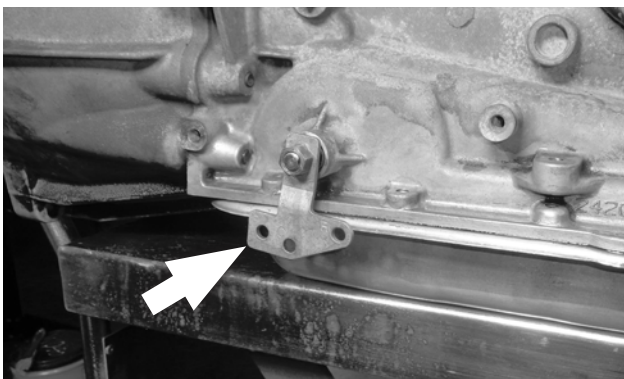

42. **Install the B&M selector lever** using the stock selector lever nut, and tighten the nut to 23 ft-lbs torque. The lever should travel smoothly back and forth, with a positive “click” in each detent.

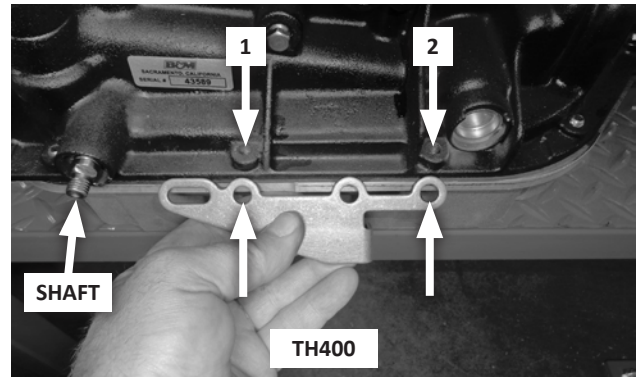
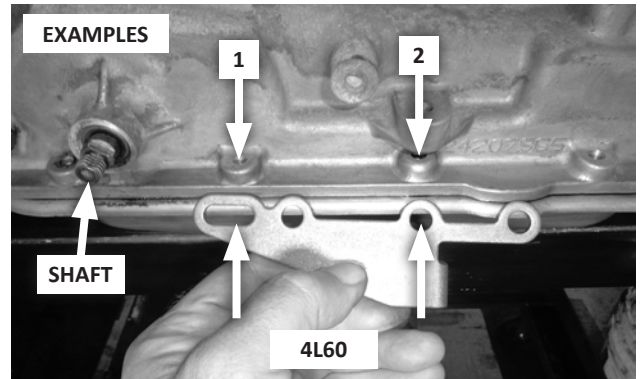

43. **Check cable bracket fit:** Remove the two oil pan bolts to the rear of the selector shaft. Determine which cable bracket holes will be used on your transmission.

**CAUTION:** To avoid stripping out your transmission’s bolt holes, use the correct bracket bolts. This kit includes both SAE and metric bracket bolts. The metric bolts have finer threads. To choose the correct kit bolts for your transmission, compare them to the stock bolts you removed.

44. **Install the cable bracket** using either the two 5/16-18 × 1" (SAE), or the two M8-1.25 × 25 (metric) bolts, and two flat washers at the bracket holes that fit your transmission.

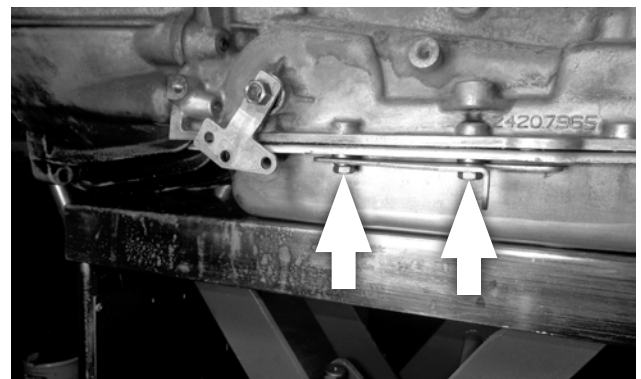

- A. **For stamped sheet-metal (stock) pans,** use the two spacers between the pan and bracket.

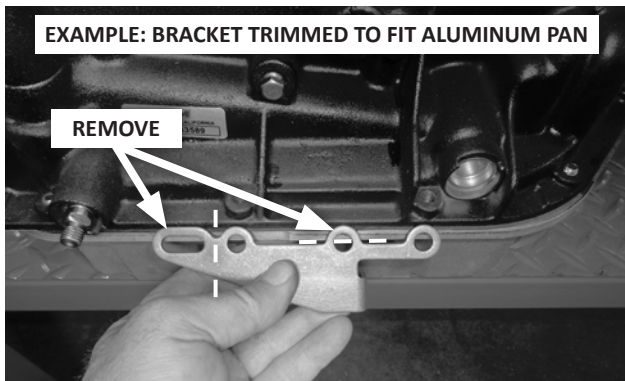

EXAMPLE: BRACKET TRIMMED TO FIT ALUMINUM PAN

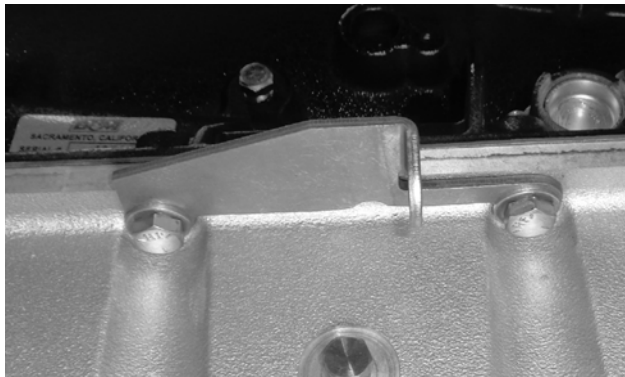

**B. For cast aluminum pans:**

- the bracket may need to be trimmed to fit; and
- the spacers are not used.

Tighten the bolts to 12-13 ft-lbs torque.

**CAUTION:** Do not over-tighten the bolts, as this can damage the pan gasket.

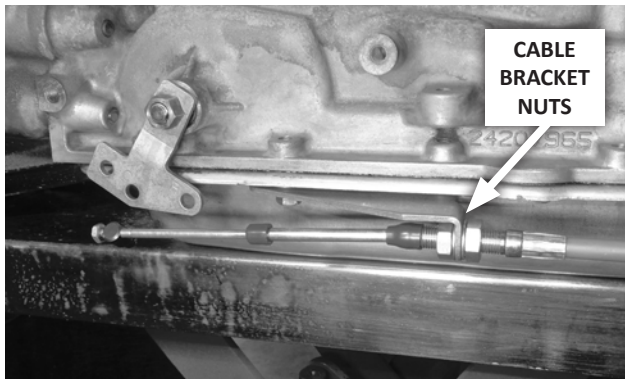

- 45. Attach the shifter cable to the cable bracket:** First remove the small jam nut, both plastic dust boots, and one large nut and lock washer, from the cable. Then insert the cable through the cable bracket, reinstall the lock washer and nut (loosely, to allow room for adjustment), and reinstall the dust boots.

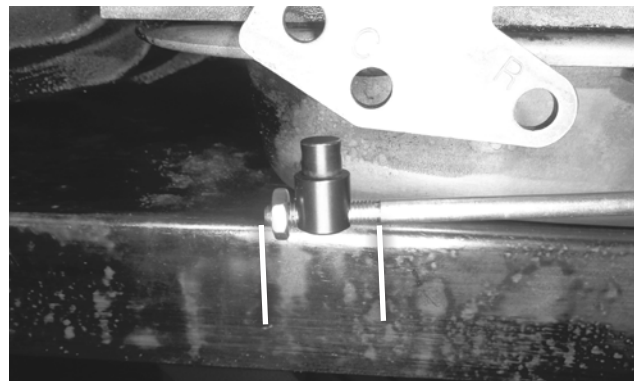

- 46. Thread the swivel onto the cable** to about the middle of the threaded section, then reinstall (but do not yet tighten) the **jam nut**.

**NOTE:** Before proceeding, verify that the speed limiter pin is either installed (for 3-speed transmissions), or removed (for 4-speeds), as described at **Step 7**.

Selector levers on GM transmissions travel twice the distance between PARK and REVERSE than they travel between the remaining positions, which is why the MegaShifter's PARK notch ("P" below) is wider than the others.

- 47. Adjust the shifter cable** as described below. (See "OPERATION" to understand the shifter's positions.)

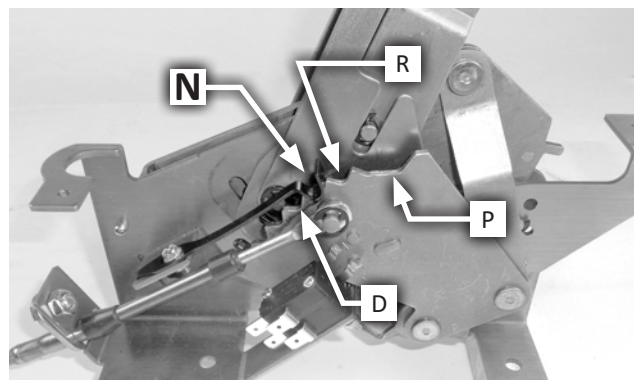

- A. On the transmission, manually move the selector lever** to the NEUTRAL detent (that is, 2 clicks back from full-forward / PARK). Then in the vehicle, move the shifter to the NEUTRAL position.

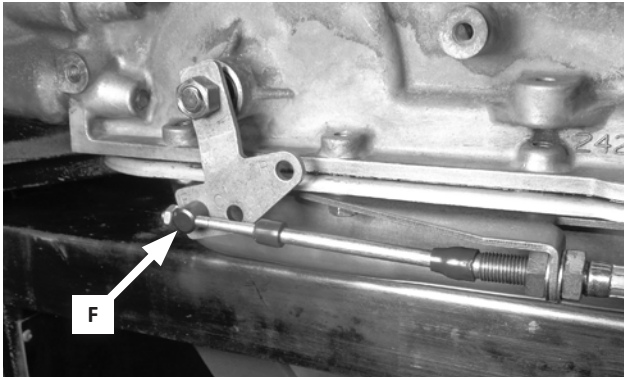

- B. Adjust cable bracket nuts (and the swivel, if necessary)** until the swivel slips freely in and out of hole “F” in the selector lever. Gradually tighten the cable nuts against the bracket while continuing to check the fit of the swivel in the selector lever.

**CAUTION:** The shifter will not operate properly unless hole “F” in the selector lever is used.

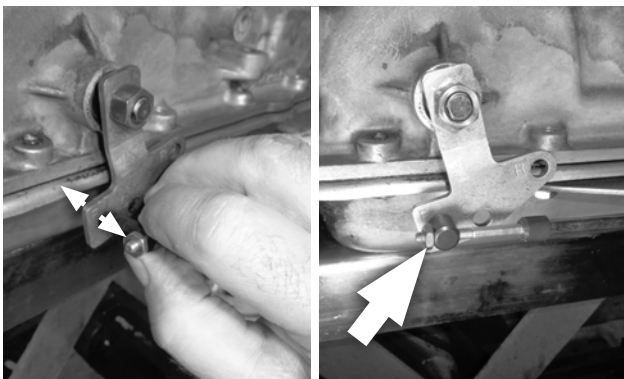

- C. When the swivel slips freely in and out of the selector lever, lightly snug the jam nut.**
- D. With the swivel still in the selector lever, move the shifter to DRIVE, and check the fit of the swivel in the selector lever.** The swivel should slip freely in and out of hole “F”. If not, adjust the cable bracket nuts (and swivel, if necessary) per **Step B**.
- E. Repeat** for both SECOND (for 3-speeds) or THIRD (for 4-speeds), and REVERSE gears.
- F. Check the swivel’s fit in FIRST (for 3-speeds), or FIRST and SECOND (for 4-speeds). THERE MAY BE A SLIGHT DRAG. This is normal; do not re-adjust the cable.**

**CAUTION:** If you encounter restricted movement or any other problem during this process, **DO NOT FORCE THE SHIFTER**. Doing so may damage the cable, the shifter and / or the transmission. Simply return to **Step A** and re-check each step.

- 48. The cable is correctly adjusted** when the swivel slips freely in and out of hole “F” in REVERSE through THIRD gears, and has a slight drag in SECOND and FIRST.

Verify that the two cable bracket nuts, and the cable swivel jam nut, are tight. Also verify that the vehicle does not roll with the transmission in PARK.

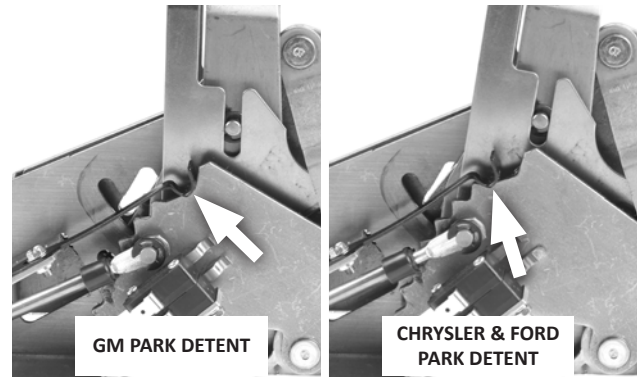

**CAUTION:** The shifter has two PARK positions — the first (lever full-forward) is for GM transmissions; and the second (one position back) is for Chryslers and Fords. **Always push the lever FULLY FORWARD to put the transmission into PARK. Otherwise the transmission’s park pawl will not engage, which will allow the vehicle to roll.** See “Operation” for further information.

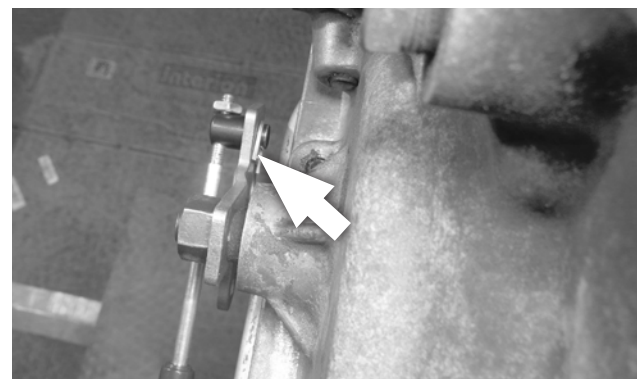

- 49. Secure the swivel to the selector lever with the cotter pin.** Operate the shifter through all the gear positions, verifying that it operates correctly.

#### NEUTRAL SAFETY AND BACKUP LIGHT SWITCHES

- 50. Determine the type of neutral safety mechanism in your vehicle.** It may be either:
- a **switch** on the stock shifter (whether on the steering column or a console); or
  - a **mechanical interlock** in the steering column that only allows the key to turn to START when the shifter is in PARK or NEUTRAL.

**51. Reroute the switch wires:** Disconnect the battery ground cable.

**A. Neutral safety switch:** Use an applicable electrical schematic to locate and identify the two neutral safety circuit wires (which prevent cranking unless the transmission is in NEUTRAL or PARK). Route both wires to the B&M shifter.

**B. Mechanical interlock:** Use an applicable electrical schematic to locate and identify the wire that runs between the START pole on the ignition switch and the starter relay or solenoid. (This is usually a purple, 10 or 12 AWG wire.) Cut the wire, and route both ends to the B&M shifter.

**52. Backup light switch:** Use an applicable electrical schematic to locate and identify the two backup light wires (usually located on the steering column behind the instrument panel). Route these wires to the B&M shifter.

**53. Wire the switches:** Strip 1/4" of insulation off the wires and crimp a **terminal** to each wire, **using an appropriate crimping tool**.

**CAUTION: Failure to use an appropriate tool to crimp the terminals may result in defective, unreliable connections.**

Tape or heat-shrink the terminal-wire connections. Connect the backup light wires to the UPPER switch, and connect the neutral safety wires to the LOWER switch (see **Step 9**).

**54. Verify switch function:** Reconnect the battery ground cable, disconnect the coil wire and set the parking brake. Check the neutral safety switch by attempting to crank the engine in each shifter position. The starter must crank only when the shifter is in either PARK or NEUTRAL. Check backup light operation with the shifter in REVERSE. If required, adjust the switches as described at **Step 9**. After verifying correct switch operation, reconnect the coil wire.



## FINISH INSTALLATION

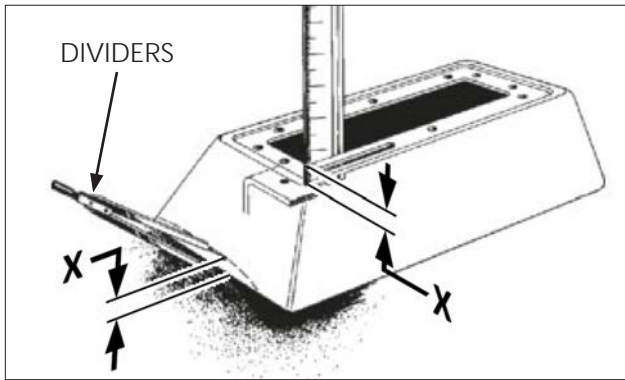

55. Place the tower over the shifter. Hold the tower level, with its bottom edge resting on the highest point on the floor that it will touch. Use a ruler to measure the dimension "X" — the distance from the shifter's tower mount tabs to the underside of the tower. Set a pair of dividers at dimension "X." While holding the tower in position, use the dividers to scribe a line on the tower to match the floor's contour. Remove the tower and use snips to remove material below the scribed line. Make small cuts, gradually working closer to the line, and continuing to check the tower's fit to the floor and shifter as you go. Once the tower is trimmed to fit, set it aside.

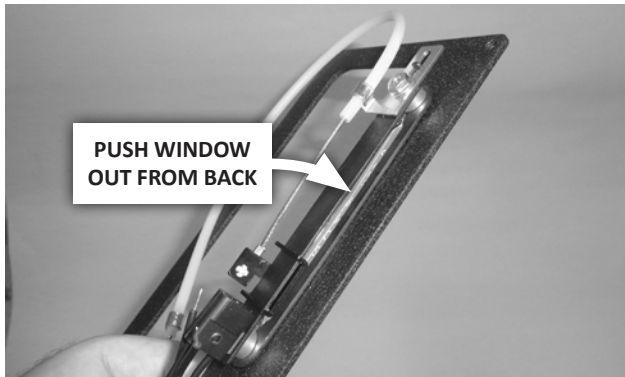

56. If you are using the shifter with a GM 4-speed transmission, replace the 3-speed indicator window in the cover assembly. From the underside of the cover, carefully push the 3-speed window out, and install the 4-speed window. (Use the 3-speed window for all other transmissions, including Chrysler and Ford 4-speeds.)

**NOTE:** The two supplied indicator windows are for standard (forward) pattern transmissions. A window for reverse-pattern 3-speed transmissions is also available from B&M.

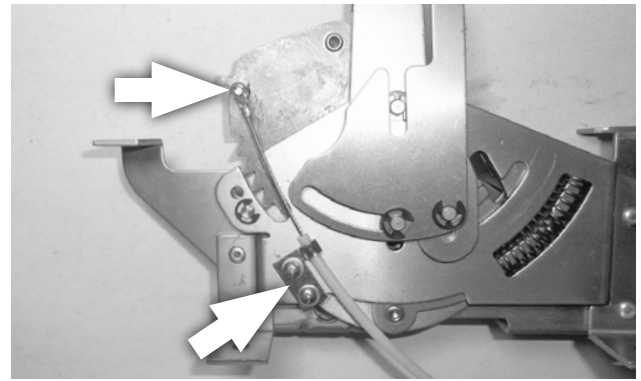

57. Attach the end of the indicator cable to its pin on the shifter with the 1/8" I.D. e-clip. Then attach the cable bracket to the shifter with the two #6 × 1/4" sheet metal screws and #6 washers.

**NOTE:** Use of a nut driver is recommended.

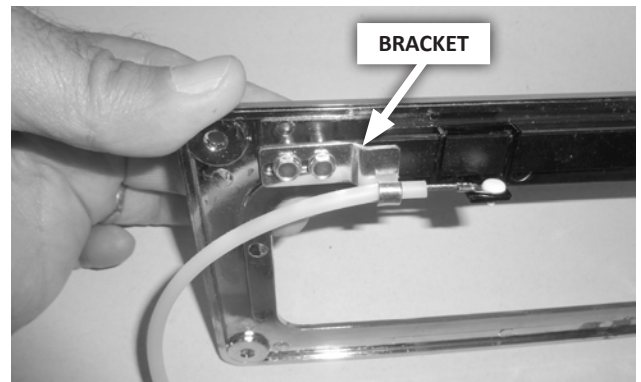

58. Run the shifter through all the gears to check indicator operation. If the indicator needs adjustment, loosen the 2 screws holding the cable bracket to the cover assembly, slide the bracket to adjust the indicator position, and re-tighten the screws carefully (they are threaded into plastic).

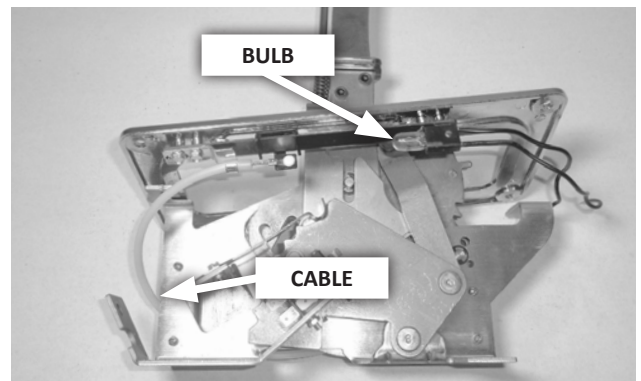

59. Gently lower the cover assembly over the shifter lever. Route the indicator cable between the front of the shifter mechanism and the shift cable mount tab. Then install the indicator bulb in its socket.



60. Verify the shifter mechanism is free of any debris or hardware. Then gently lower the tower over the shifter, and carefully feed the cover assembly up through the tower, maintaining the location of the indicator cable from the previous step.

61. **Wire the indicator light.** Run a power wire from the vehicle's instrument light circuit to the shifter, and connect it to one of the indicator's wires. Connect the indicator's other wire to a suitable chassis ground (for example, a shifter mount bolt).

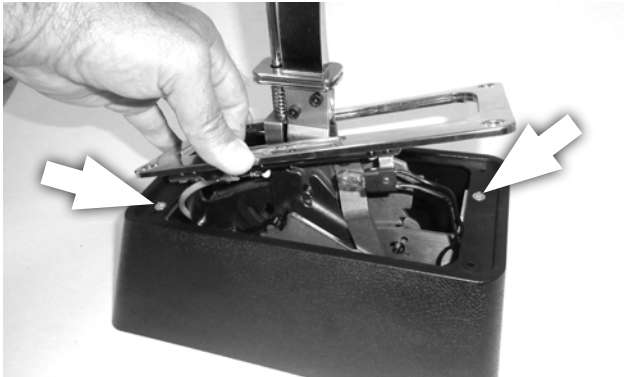

62. Secure the tower to the shifter with the two 1/2" flat head Phillips screws.

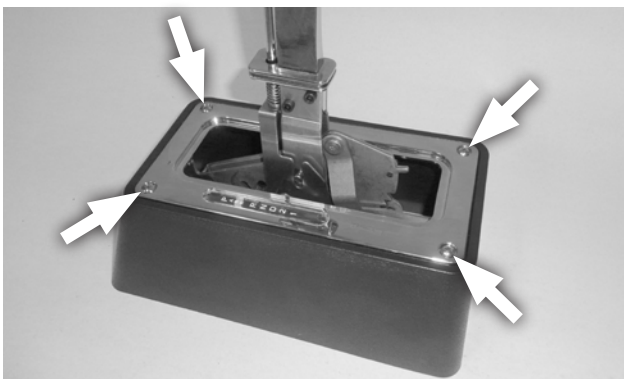

63. Secure the cover assembly to the tower with the four 3/4" self-tapping Phillips head screws.



64. Remove the T-handle, then slide the shifter boot over the stick. Work the boot's bottom groove onto the inside edge of the cover, and work its top groove onto the **bottom flange** on the shift lever. (The top flange will sit atop the boot.)

65. Apply medium strength thread locking fluid to the threads at the top of the shifter lever.

**CAUTION:** If thread locking fluid is not used, the T-handle's threads may gall, making it impossible to remove it from the stick in the future.



66. Carefully thread the T-handle all the way onto the stick.

**CAUTION: Avoid cross-threading!** The T-handle should spin freely onto the stick with no resistance. **If you start to feel any resistance, STOP,** remove the handle, align the threads properly, and try again.

Align the T-handle as desired, then tighten the jam nut.

67. Fasten the carpet to the vehicle floor.

**Congratulations! Your B&M MegaShifter™ is now installed and ready to use.**

## INSTALLATION CHECKLIST

- Locking steering column lever is permanently fastened in the full up position (Step 1).
- Shifter is convenient to reach and has ample room for driver's hand throughout its range of motion (Step 3).
- Carpet covers floorboard holes (Step 6).
- Cable is connected to the shifter pin, and cable housing is securely fastened to the shifter base (Step 8).
- Shifter is securely mounted to floorboard (Step 10).
- Cable is routed clear of exhaust system, engine, and any moving parts (Step 11).
- Selector lever is securely installed on the transmission (Step 14, 29, or 42).
- Cable bracket bolts are tightened to 12-13 ft-lbs torque (Step 15, 30, or 44).
- Shifter is properly adjusted; cable boots are installed; cable nuts are tightened; swivel is secured with jam nut and cotter key (Steps 18-20; 33-35; or 47-49).
- The neutral safety switch is connected and properly adjusted to prevent engine start in FORWARD and REVERSE drive gears (Steps 37-39; or 50-54).
- There is no debris in the shifter mechanism (Step 60).
- Indicator light is properly wired (Step 61).
- Tower, cover and boot are installed (Steps 62-64).
- Shifter moves freely into and out of all positions, as described in Operation.

**CAUTION: If your shifter is not working properly do not attempt to drive your car!** Verify you have followed all instructions. If the shifter is broken or defective, return it to your B&M dealer.

## OPERATION

**NOTE:** The shifter positions referred to below apply to standard-pattern transmissions (P-R-N-D-2-L). Reverse-pattern transmissions (P-R-N-L-2-D) will alter your shifter-transmission positions accordingly.

The B&M MegaShifter™ operates in “straight gate” mode from PARK through DRIVE. (In PARK, the reverse lockout trigger must first be lifted to shift into REVERSE.)

When the shifter moves from NEUTRAL into DRIVE, it enters the “ratchet shift” range (from NEUTRAL to LOW). To shift the transmission in “ratchet shift” mode, pull or push the shifter handle to a full stop then release it, allowing it to return to its “centered” position. Repeat this action until the transmission is in the desired gear.

The shifter only operates in “ratchet shift” mode between LOW and NEUTRAL, to prevent unintended shifting into REVERSE. To shift from “ratchet shift” back to “straight gate” mode, shift the transmission to DRIVE, lift the reverse lockout trigger, and push the handle forward into NEUTRAL, REVERSE or PARK.

The shift range diagram will help you to better understand how to operate the MegaShifter. And the photos below explain the correct shifter position for putting your transmission in PARK.

If the instructions seem complicated at first, not to worry — the MegaShifter is easy to operate after just a brief time of familiarization.

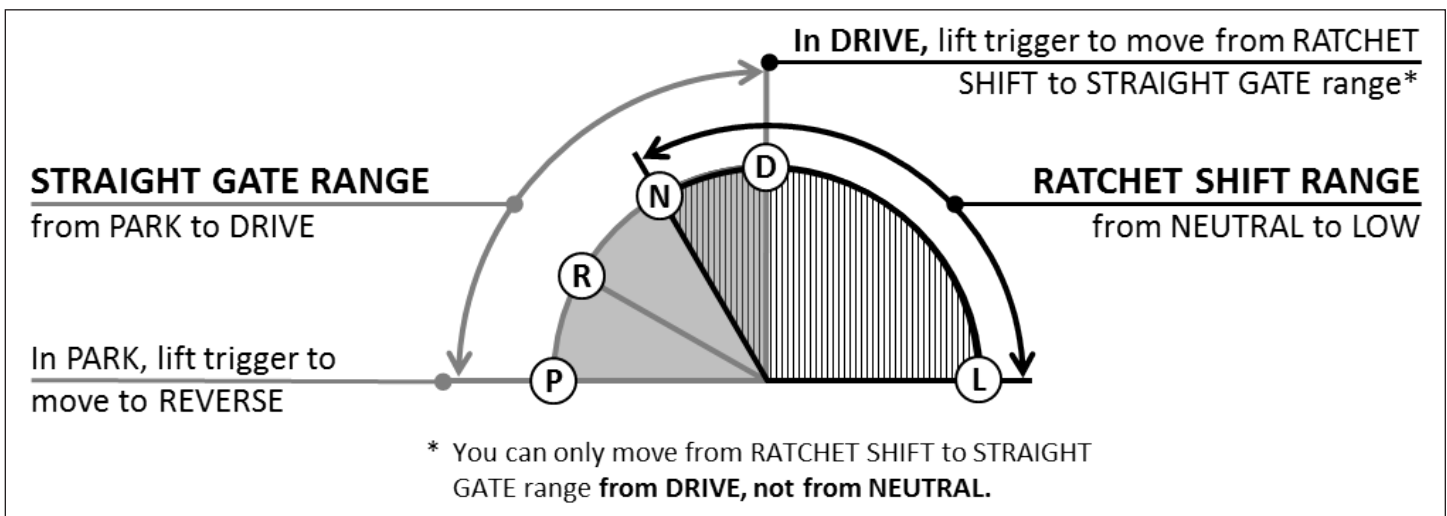

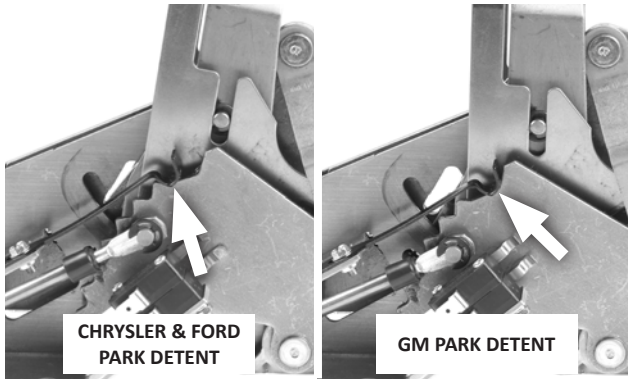

Note the correct shifter position for putting your transmission in PARK:

- **CHRYSLER & FORD:** To avoid stretching the shifter cable, **NEVER force the shifter past the second (rear) PARK detent**, which corresponds to your transmission selector lever's PARK position.
- **GM:** Always push the shifter lever **FULLY FORWARD to put the transmission into PARK**. Otherwise the transmission's park pawl will not engage, which will **allow the vehicle to roll**.

#### KEEP THESE INSTRUCTIONS FOR FUTURE REFERENCE

B&M Performance & Off-Road maintains a highly-trained technical service department to answer your technical questions, provide additional product information and offer various recommendations.

**B&M TECHNICAL SUPPORT: (866) 464-6553**

