



Installation Instructions  
**70244**  
CONVERTER LOCK-UP CONTROL  
TH700-R4/4L60, 200C, 200-4R & 350C

## INTRODUCTION:

**NOTE:** This kit is designed for transmissions equipped with a mechanically driven speedometer cable. Use kit #70248 with transmissions equipped with electronic speed sensor.

1. B&M's Converter Lock-Up Control provides driver control of the speed where converter clutch lock-up takes place. This dash mounted electronic control module has a dial to adjust lock-up speed; a two color LED (Light Emitting Diode) that indicates lock-up clutch status and a power on/off button. The Converter Lock-Up Control module receives a signal from the supplied speedometer cable mounted sensor. This signal along with the dial setting determines the precise speed at which to activate the lock-up clutch solenoid. Whenever the ignition is on and power button is engaged but the vehicle is stopped or moving slowly the LED is RED (lock-up clutch off). When the vehicle reaches the speed preset by the dial on the Converter Lock-Up Control module, the LED turns GREEN and power is available to the lock-up clutch solenoid. This will activate the solenoid and cause the converter clutch to lock-up. Once the transmission has shifted beyond first gear and the solenoid is activated, lock-up will occur at any speed within the range of the Lock-Up Control. B&M's Converter Lock-Up Control will not cure a defective converter clutch, however if the clutch is not defective the B&M Converter Lock-Up Control will lock it at the preset speed.

**WARNING:**

When using this Converter Lock-Up Control with any four speed overdrive transmission, we recommend the lock-up speed not be set higher than 45 MPH. Operation in fourth gear (Overdrive) without converter clutch locked-up can result in transmission and engine overheating.

## PREINSTALLATION:

2. Before installing your B&M Converter Lock-Up Control, we recommend that you perform a few simple transmission performance checks and make sure you have certain tools and equipment on hand to assist in the installation.

## LOCK-UP CLUTCH OPERATION:

3. Operate vehicle with range selector in third gear (Drive) position. Choose an area where you will not exceed the local speed limit. Verify proper operation of lock-up clutch and transmission. Accelerate the vehicle at low speed until it shifts into third gear. Lock-up clutch operation (in stock vehicles) can usually be checked by operating the vehicle at a steady speed and lightly depressing the brake pedal just enough to activate the brake light switch. Alternatively, depress the throttle a small amount but rapidly, this should cause the lock-up clutch to disengage, then rapidly return throttle to steady speed position and lock-up clutch should reengage. When the lock-up clutch engages and disengages you should notice a 200-500 RPM change in engine speed. If the lock-up clutch is defective replace the torque converter.

## TRANSMISSION PERFORMANCE:

4. Check overall transmission performance for shift quality and timing. If performance seems sluggish or shift timing is occurring too early or late check vacuum lines and transmission throttle valve or detent cable adjustment. Check transmission oil pressures and compare them to the appropriate service manual for your vehicle. If the problems persist, B&M has a complete line of products for rebuilding and enhancing the performance of GM transmissions.

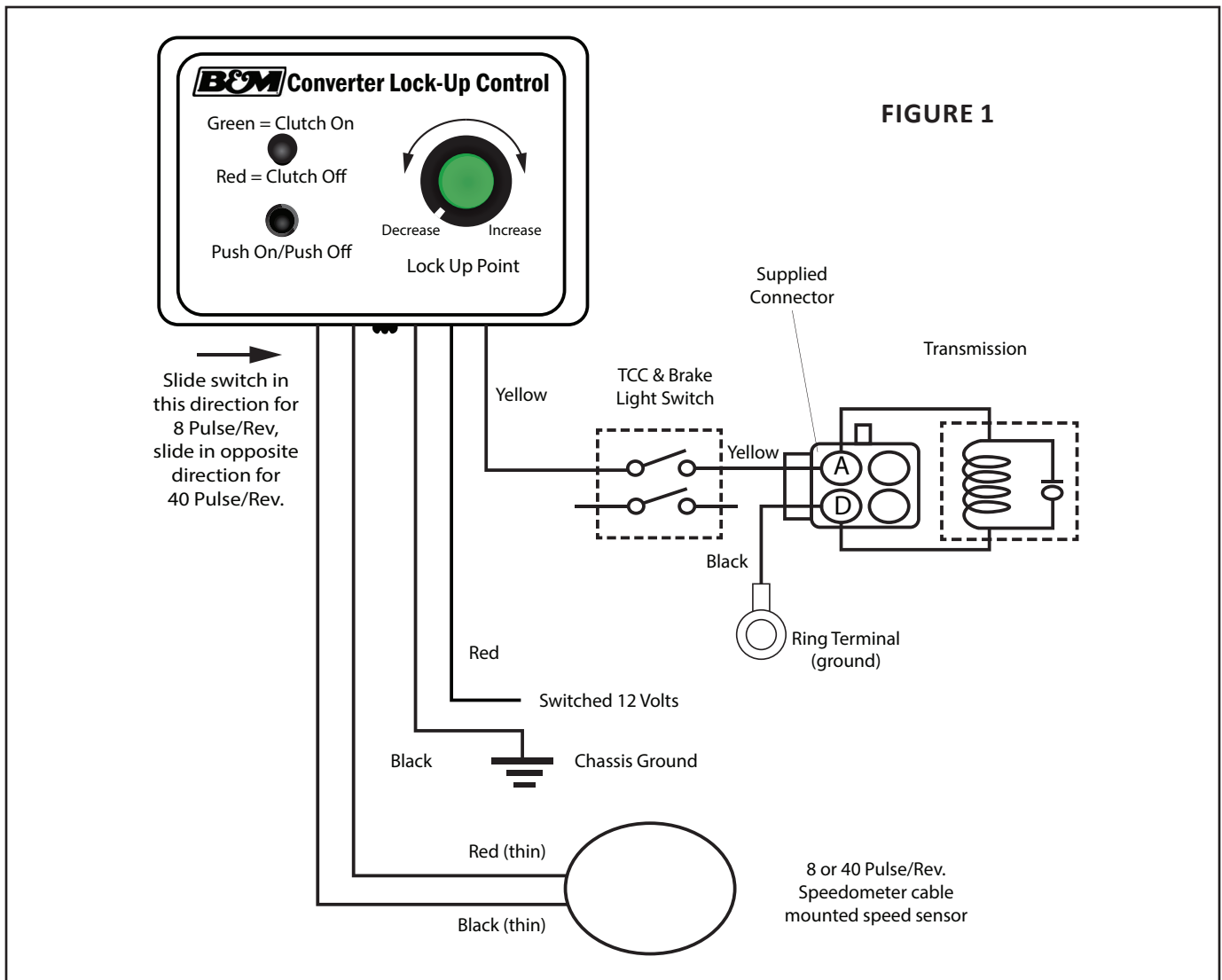

**FIGURE 1**

**INSTALLATION:**

- Installation of B&M’s Converter Lock-Up Control requires clear access to the underside of the vehicle in order to properly route wires and install speed sensor. Raise vehicle so there is 2 feet or more ground clearance.

**WARNING:**  
 Securely support vehicle with jack stands, wheel ramps or a hoist. Do NOT use jacks on their own.

**WIRING REQUIREMENT:**

The B&M Converter Lock-Up Control is relatively simple to hook up. There are five wires connected to the Converter Lock-Up Control module which are color coded and have the following functions:

COLOR	FUNCTION
Red	+12V, 5A-10A fused, ignition key controlled source.
Black	Chassis ground.
Yellow	Supplies +12V to transmission lock-up clutch solenoid.
Red (thin)	Speed sensor.
Black (thin)	Speed sensor.

Installation requires hooking up only the Red, Black and Yellow wires. The Black (thin) and Red (thin) wires are already connected to the speed sensor unit.

**STANDARD INSTALLATION:**

- Choose an accessible location on dash to mount Converter Lock-Up Control module. Clean surface with rubbing alcohol, remove backing from hook & loop tapes then install module.

7. Locate ignition key controlled 5A-10A fused source of +12V and a good chassis ground connection. Most GM fuse panels have an instrument section that can be tapped to supply the Converter Lock-Up Control module. Use a VOM (Volt-Ohm Meter) or a test light to check the continuity and voltage between the proposed power source and ground.
8. Connect the Red wire to +12V power source and the Black wire to ground connection located in STEP 2. Reversing the polarity of these two wires will damage the Converter Lock-Up Control module and VOID THE WARRANTY. Route wires so they cannot become tangled in any mechanisms (brake pedals, A\C, heater controls).
9. Route remaining wires from the Converter Lock-Up Control module to the transmission. Make sure wires passing through the fire wall or floor pan are adequately protected against abrasion with the sheet metal. Also take care not to route wires near hot exhaust pipes and high tension ignition wires. The heat will melt insulation from wires and the ignition pulses can cause unpredictable Converter Lock-Up Control operation.
10. Disconnect the speedometer cable at the transmission end. Install the short adapter cable supplied with kit on the transmission making sure cable core is engaged in transmission fitting. Next install the speed sensor and connect speedometer cable to the other side. Rotate sensor so that wires do not hang down and are out of the way of any moving mechanism or hot pipes.
11. For most applications connect the Yellow wire as shown in Figure 1 which shows the proper wiring hookup for the Converter Lock-Up Control. This diagram shows the stock TCC (Torque Converter Clutch) and brake light switch with the yellow

wire feeding through the switch and continuing down to the 'A' terminal on the connector going into the transmission. For ease of convenience, the kit is supplied with the yellow wire and a black grounding wire attached to a connector that will plug directly into the transmission. This yellow wire can be cut and routed to the brake light switch and then continue to the Converter Lock Up Control. The short black wire can be attached to a transmission pan bolt to ground the circuit. In custom applications you can bypass the brake light switch, and you can plug the supplied transmission connector directly into the transmission and ground the short Black wire from pin D. We recommend that you wire the Converter Lock-Up Control through the brake switch as a safety precaution. The brake switch disengages the lock-up clutch upon brake application in the unlikely event of an electrical malfunction. Route wires next to members where they can be secured. Once again remember to avoid mechanisms and hot pipes which can fray or melt the insulation and cause a short circuit.

#### OPERATION:

12. Operation of your B&M Converter Lock-Up Control is automatic once it has been preset to the desired lock-up speed. When properly connected the Red LED on the front of the Converter Lock-Up Control should light when the ignition key is turned on (if it does not, please inspect the Red & Black wires). Lock-up engagement speed is adjusted while operating the vehicle. Operate the vehicle at the speed where you want the lock-up to be engaged continuously. Turn the knob until the Green LED lights and the converter clutch lock-up occurs. The lock-up engagement speed can be changed at any time to suit driving conditions by turning the knob left or right as desired.

**FIGURE 2**

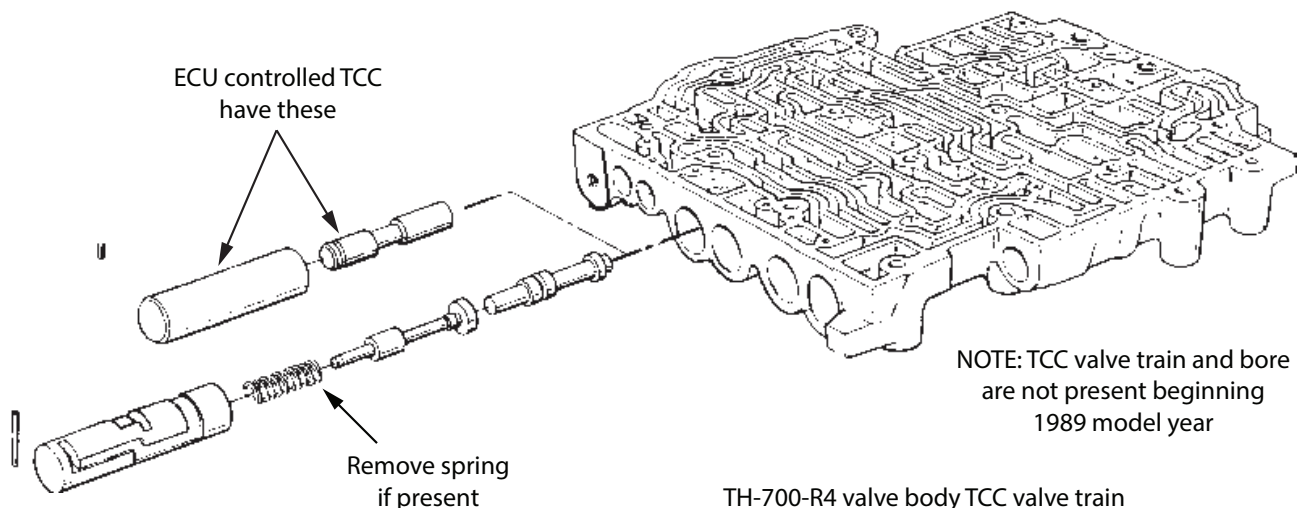

## CUSTOM TRANSMISSION INSTALLATION:

13. B&M's Converter Lock-Up Control is specially suited for controlling the lock-up clutch in vehicles with custom transmission installations which were not originally manufactured with a torque converter clutch equipped transmission. Custom transmission installations utilizing early model transmissions with valve body controlled lock-up (TH-200-4R, TH-700-R4) speed may require some modification to operate correctly. In these cases consult the appropriate factory service manual to locate the converter clutch shift valve train in the valve body. Deactivate the converter clutch shift valve by removing the spring holding the shift valve in the OFF position. This will allow the converter clutch shift valve to move to the ON position and ensure that control pressure is always available at the converter clutch apply valve after the first gear shift. A TH-700 converter clutch shift valve train is shown in Figure 2 as an example. It may also be necessary to remove the oil pan and identify which kind of solenoid and wiring scheme is used on your particular unit. A prewired four pin transmission connector (attached to the Converter Lock-Up Control module) is provided for these applications.

## LOCK-UP CLUTCH AND SOLENOID BASICS:

14. The lock-up clutch is located inside the torque converter and is designed to eliminate torque converter slip for improved efficiency. In GM vehicle's the speed at which lock-up clutch engagement occurs is controlled either by hydraulic circuits inside the transmission or by the vehicle's Electronic Control Unit (ECU). Lock-up clutch engagement occurs when the Converter Clutch Apply Valve changes position and vents the area behind the lock-up clutch piston. The

converter clutch apply valve's position (on/off) is determined by the converter clutch solenoid and the availability of control pressure. In most early applications the solenoid is always energized and control pressure is supplied by a shift valve in the valve body which determined at what speed lock-up occurred. Later applications eliminated the shift valve altogether and supply control pressure continuously. In the later units the ECU is used to energize the solenoid at the appropriate speed by providing an external ground to the solenoid. In all of the above cases control pressure becomes available only after the transmission shifts out of first gear. Hence the torque converter clutch will never lock-up in first gear. The converter clutch solenoid is located inside the transmission, as are the converter clutch apply valve and, if equipped, Converter Clutch Shift Valve. Access to these components requires oil pan removal. Some applications may require inspection or modification of these components.

15. The lock-up solenoid is connected to a four pin (some early units have two pins) connector located on the transmission case. The pins on these connectors are identified by letters A, B, C and D.
16. Lock-up solenoids come with either one or two wires. The one wire style is internally grounded and requires only a +12V connection to energize. One wire solenoids are generally hooked up to connector pin A, see Figure 3. Two wire solenoids require both +12V and ground connections to operate. Two wire solenoids are usually hooked up to pins A and D, where A is +12V and D is ground, see Figure 4. Depending on the application one or both of the solenoid wires may also be connected to pressure switches on the valve body either before, or instead of, going to pin D. Reversing the polarity on a two wire solenoid can damage an internal diode which protects the electrical system from voltage spikes.

FIGURE 3

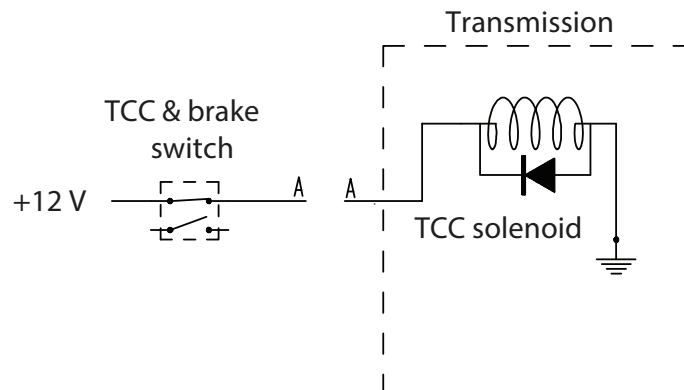

**FIGURE 4**

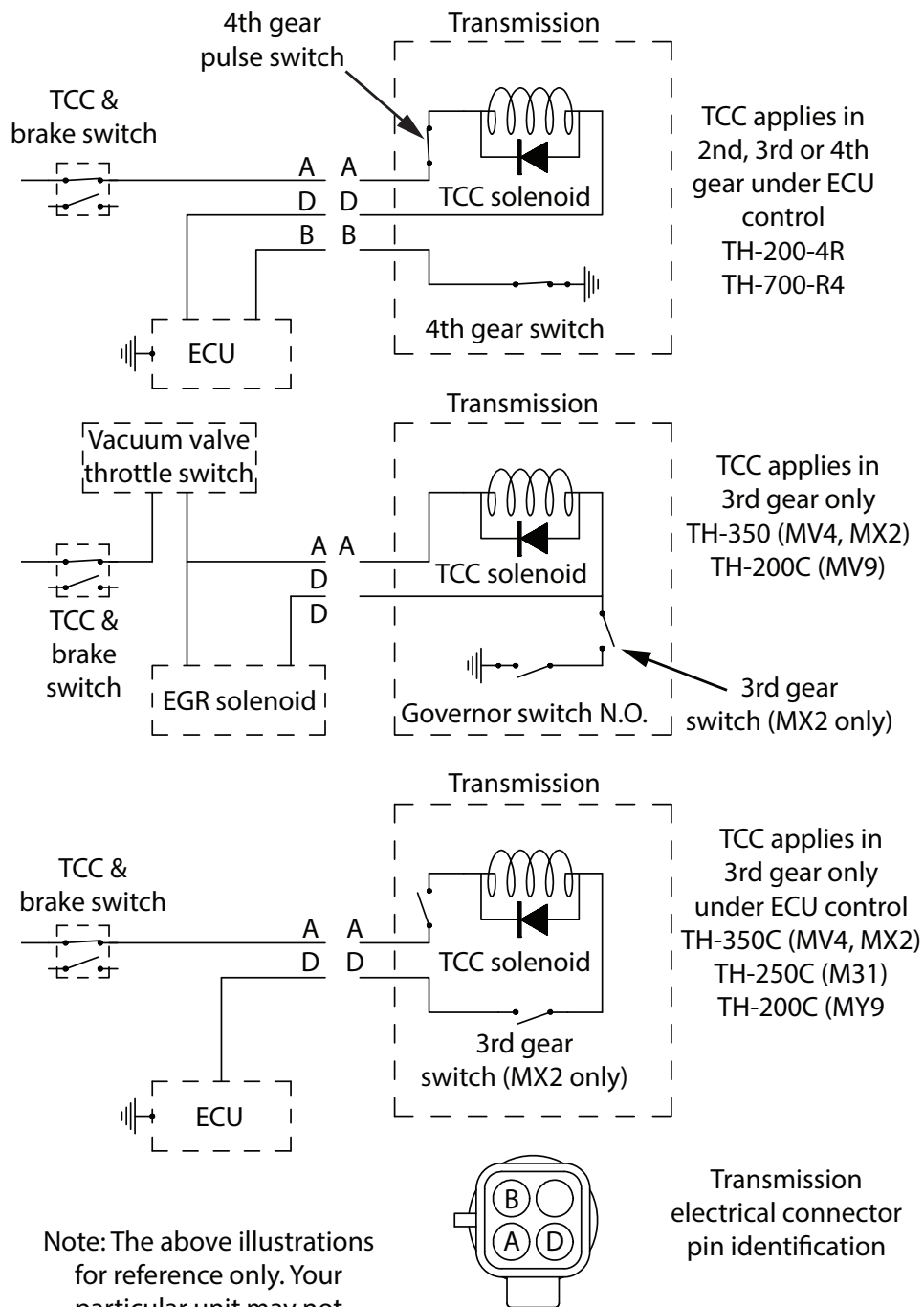

Note: The above illustrations for reference only. Your particular unit may not have all components shown.

**TOOLS:**

- Besides the normal electrical repair tools i.e. wire cutters, stripper and terminal crimper, a VOM (Volt Ohm Meter, or at the very least a 12V test light) is required to check voltage polarity and circuit continuity. Incorrect polarity connections or short circuits will damage the Converter Lock-Up Control electronic module and void the warranty.

Congratulations, the installation of your **B&M Converter Lock-Up Control** is now complete!

