



INSTALLATION INSTRUCTIONS

Part No. 45044

PRECISION MANUAL SPORTSHIFTER™

for 1997-2007 Chevrolet Corvette (C5 & early C6)
with manual transmission

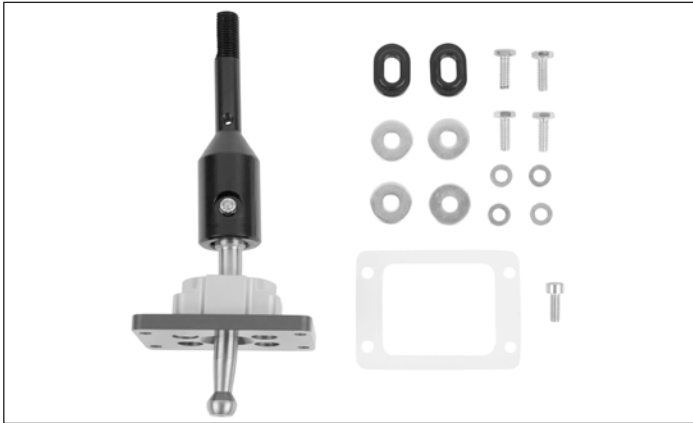

- If you do not understand any part of these instructions, please call **B&M Technical Support** at (866) 464-6553 for assistance.

REQUIRED ITEMS

- White lithium grease
- Medium-strength thread locking compound (Permatex Blue or similar)
- Plastic trim tools (for removing interior panels)

1997-2004 (C5) MODELS

REMOVE THE STOCK SHIFTER

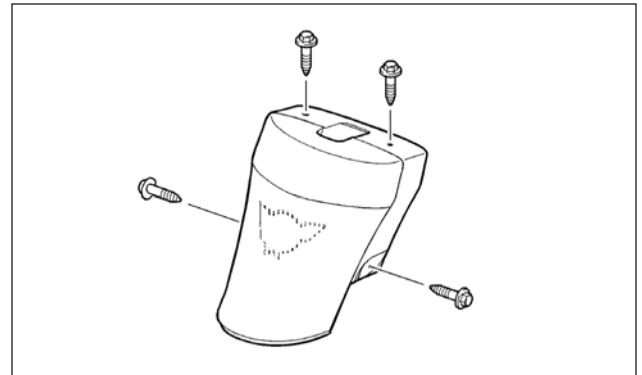

1. **CONVERTIBLES ONLY:** Remove the “waterfall” (the plastic panel between the seat backs). For access, put the top down, but leave the deck lid up. Remove the 2 screws on top of the waterfall, and 1 screw on each side (4 screws total). Then remove the waterfall.



2. Remove the shift-pattern insert from the shift knob with a small, flat-tipped screwdriver.

PARTS LIST

DESCRIPTION	QTY
SHIFTER ASSEMBLY	1
GASKET, SHIFTER	1
SCREW, 1/4-20 × 3/4"	4
WASHER, FLAT 1/4"	4
BUSHING, ANODIZED (OPTIONAL)	2
WASHER, FLAT M8 OVERSIZED (OPTIONAL)	4
SCREW, FLAT HEAD M6-1.0 × 16	1

BEFORE STARTING

Take a moment to read and understand the instructions for your vehicle. **C5 instructions start on this page; and C6 starts on p. 8.**

Use the parts list to verify your kit’s contents. In the unlikely event that any parts are missing, please contact B&M Technical Support for replacements.

We recommend that you retain all factory parts.

WORK SAFELY! Park the vehicle on a clean, level surface. Turn the ignition switch **OFF**. Chock the wheels, and set the parking brake before starting.

NOTES

- Installation requires moderate mechanical skill. If this job is beyond your abilities, seek the services of a qualified technician.
- The shifter mechanism is precision-assembled at our factory. **Any modification or disassembly of the shifter will void its warranty, and may cause it to malfunction.** Disassemble items **only** where specified in the instructions.



3. **Remove the T-shaped key from the knob.** (It may be pried up with 2 flat-tipped screwdrivers — one on each side of the key's T-shaped head — or pulled out with locking pliers.) Then unscrew the knob from the shift lever.

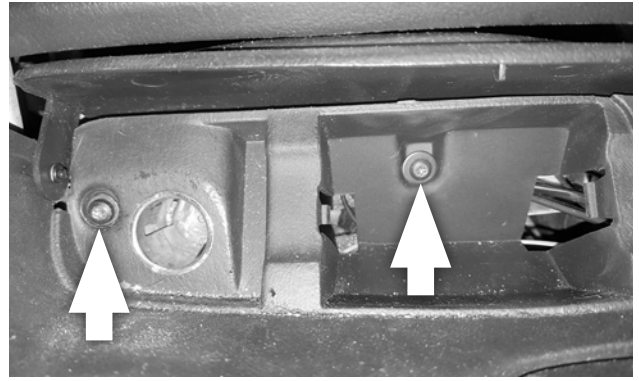

6. **Remove the ash tray.** Then remove 1 screw behind the ash tray, and 1 screw next to the cigarette lighter.

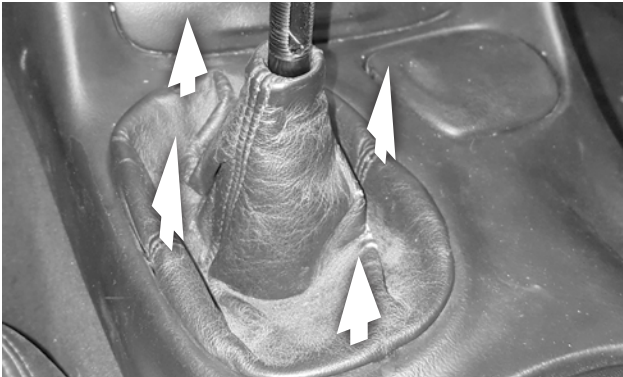

4. **Separate the shift boot frame from the front console,** lift the boot over the lever, and set it aside.

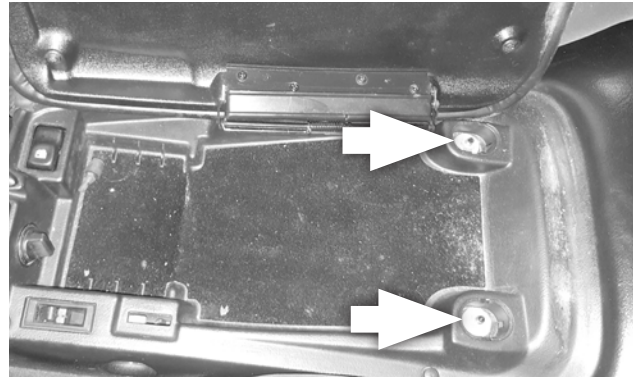

7. **Open the center console lid.** Remove the 2 plastic trim covers and the 2 nuts at the rear of the storage compartment.

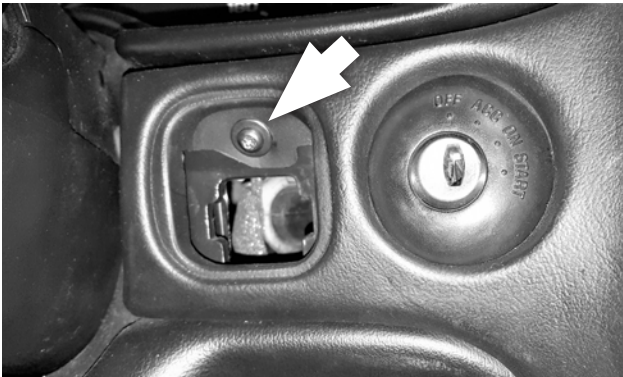

5. **Remove the small grille to the left of the ignition switch,** then remove the screw behind it.



8. **At the front edge of the storage compartment,** lift up on the rear edge of the half-round panel to detach it from the front console. Disconnect any electrical plugs, and set the panel aside.

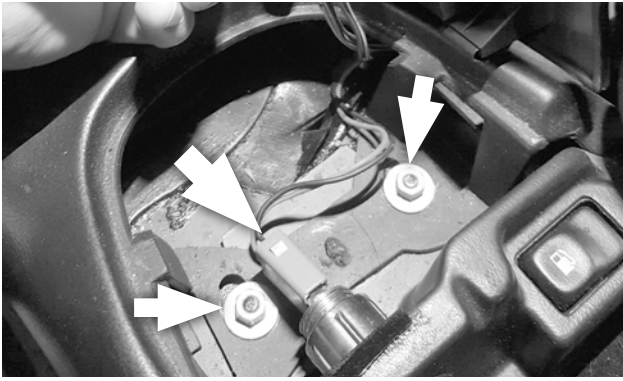

9. Disconnect the electrical plug from the 12v receptacle, then remove the two nuts.

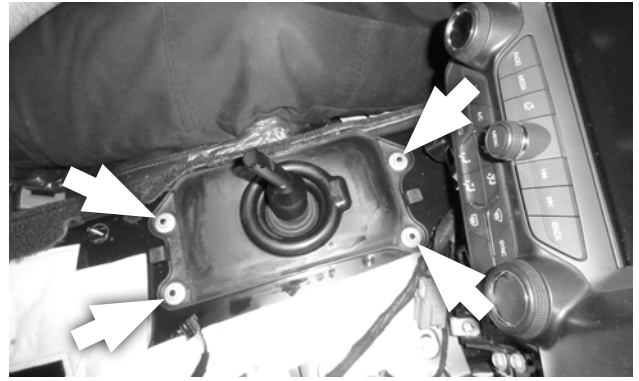

12. Remove the 4 nuts and the rubber dust boot and set them aside.



10. Lift the rear of the center console and move it back just far enough for the 12v receptacle to clear the front console.

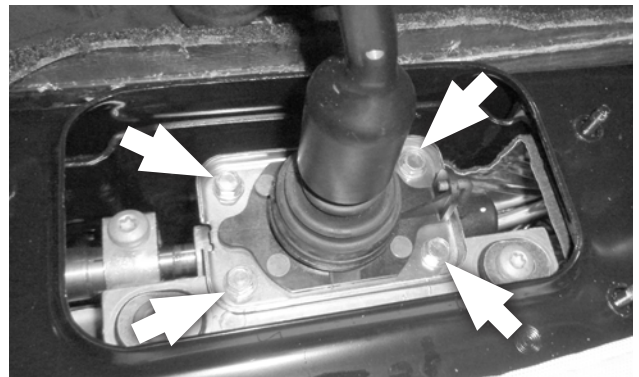

13. Put the shifter in Neutral. Then remove the 4 mount bolts and the shifter assembly, and remove any gasket material from the mount pad.

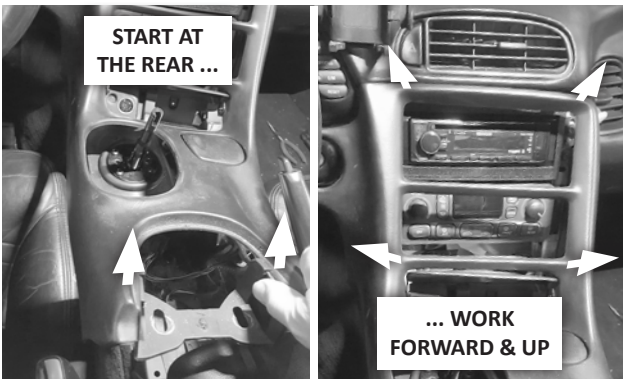

11. Starting at the rear and working forward, detach the front console from the console base and dash. Disconnect the cigarette lighter plug, and set the front console aside.

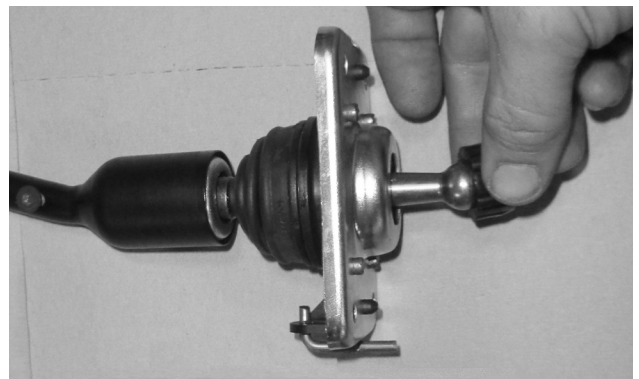

14. Remove the plastic pivot cup from the shift lever.

CAUTION: The pivot cup will be re-used. It should snap off by hand, but if you use pliers, take care not to damage it.

OPTIONAL: REPLACE RUBBER STOCK BUSHINGS

This section (**Steps 15-20**) describes the replacement of the rubber stock bushings with the optional metal bushings included in this kit. (This does not apply to the Z06, which already uses metal bushings.)

Use of the metal bushings provides a more solid-feeling shift. However, it also transmits more noise and vibration to the passenger compartment. If a quieter, smoother shift is preferred, skip this section and proceed to **Step 21**.

NOTE: Handle all hardware with care to prevent it from falling into the shifter cavity.

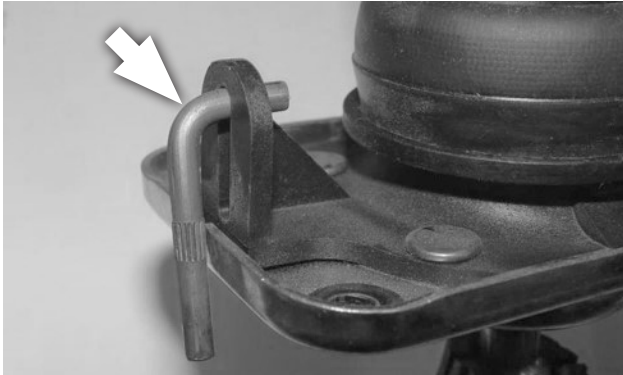

15. Remove the L-shaped alignment pin from the front of the stock shifter.



16. Insert the "L" pin FULLY into the hole in the shift linkage support in front of the shift box.

CAUTION: Full insertion is required to maintain shift linkage alignment while replacing the bushings.



17. Remove the two screws that secure the shift box to the vehicle.



18. Remove the metal spacers and rubber bushings from both holes.

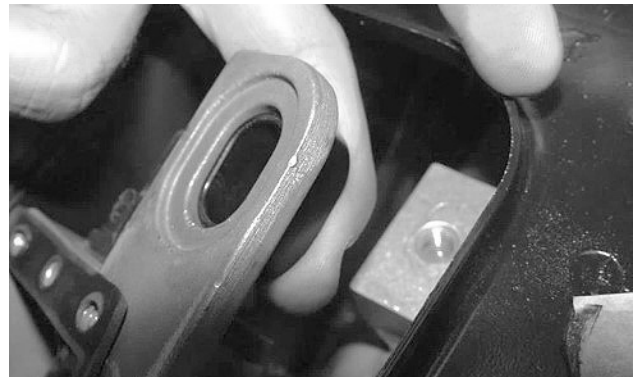

19. Lift the right side of shift box slightly, insert the kit's 2 metal bushings into the holes from the underside, then return the box to its normal position.



20. Apply medium-strength thread locker to the stock screws and reinstall them, along with the kit's 4 washers (2 per screw). After tightening both screws, remove the "L" pin.

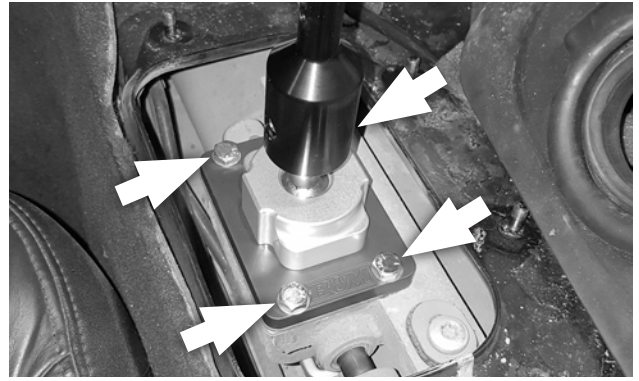

23. Place the shifter on the shift box, inserting the pivot cup into the shift linkage.

NOTE: Place the B&M logo toward the back, so that the shift lever is correctly tilted rearward.

Apply medium-strength thread locker to the four 1/4-20 screws, and secure the shifter to the shift box with the screws and 1/4" washers.

INSTALL THE B&M PRECISION SPORTSHIFTER

CAUTION: To avoid cracking the plastics during reassembly of the vehicle interior, do not over-tighten the screws.

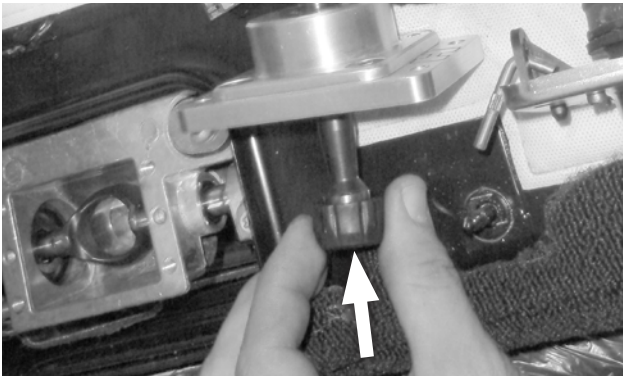

21. Grease the pivot ball at the bottom of the B&M shifter's lever. Then snap the stock pivot cup onto the pivot ball.

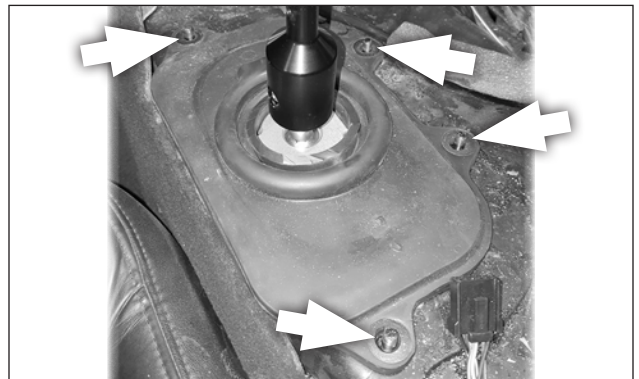

24. Reinstall the rubber dust boot using the 4 stock nuts.

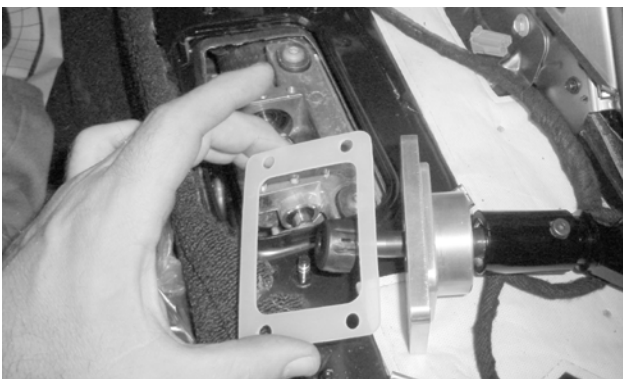

22. Install the new gasket on the mount pad.

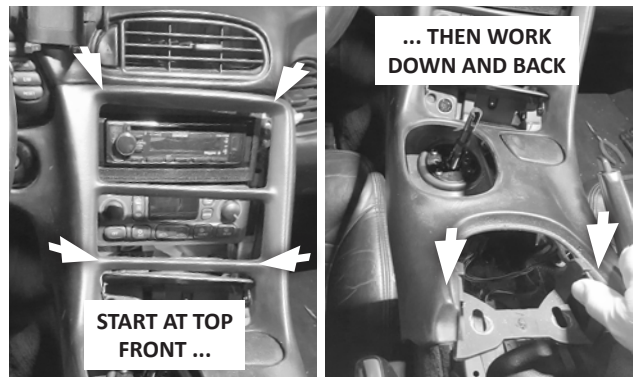

25. Move the front console close to the dash and console base, and reconnect the cigarette lighter plug (front of console). Reassemble the console to the dash first, then to the console base.

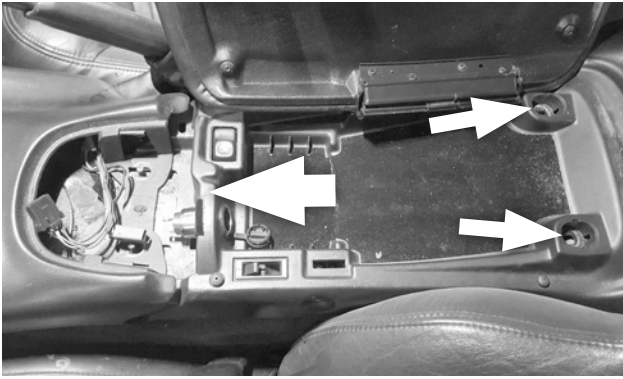

26. Slide the center console forward and lower the rear mount holes onto their studs.

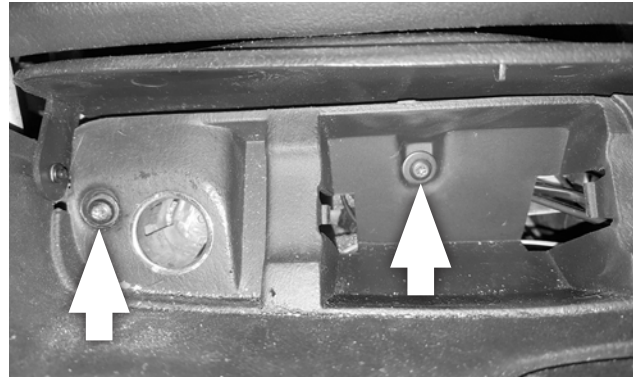

29. Reinstall the 2 lower screws (at the ash tray and cigarette lighter), then reinstall the ash tray.

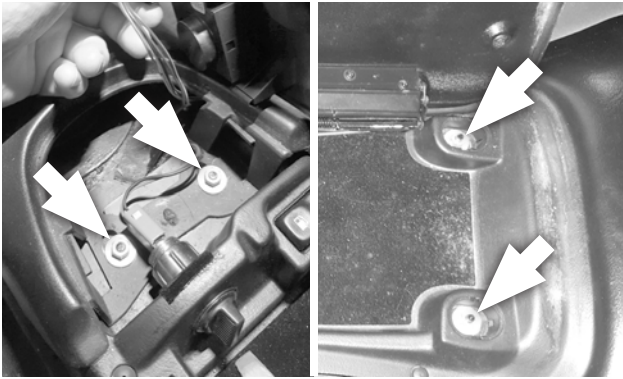

27. Hand-start the 2 front and 2 rear center console nuts, then tighten them all down. Reconnect the plug to the 12v receptacle, and reinstall the trim covers over the rear nuts.

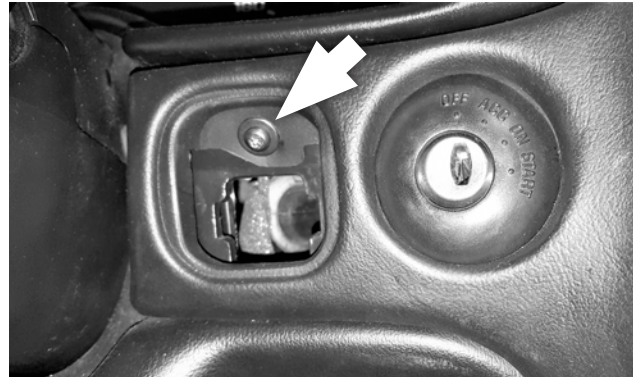

30. Reinstall the upper screw (next to the ignition switch), then reinstall the small grille.

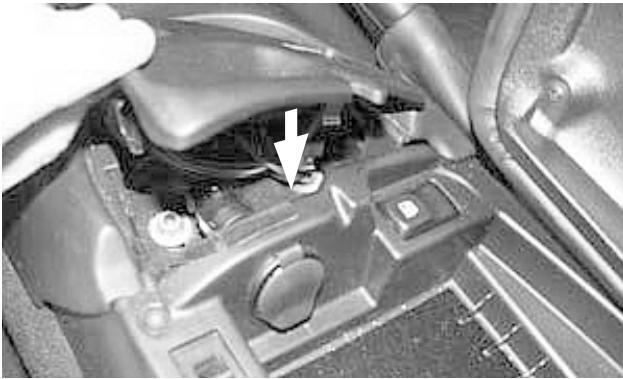

28. Reconnect any electrical plugs to the half-round panel, then reinstall the panel in the console.

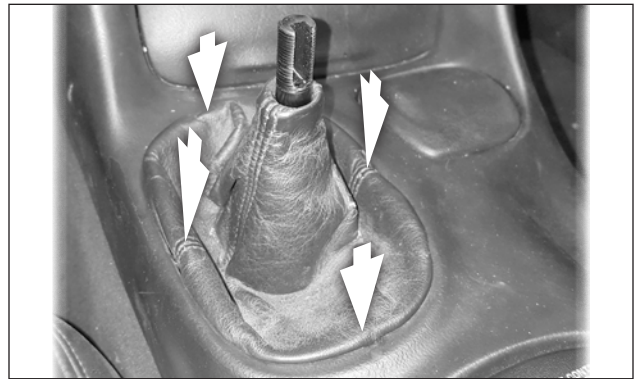

31. Place the shift boot over the shift lever, and snap it back into place in the front console.



32. Thread the shift knob onto the shift lever, aligning the keyhole with the keyway in the shift lever.



33. Use a hammer and punch to re-install the locking key, then snap the shift-pattern insert back into place.

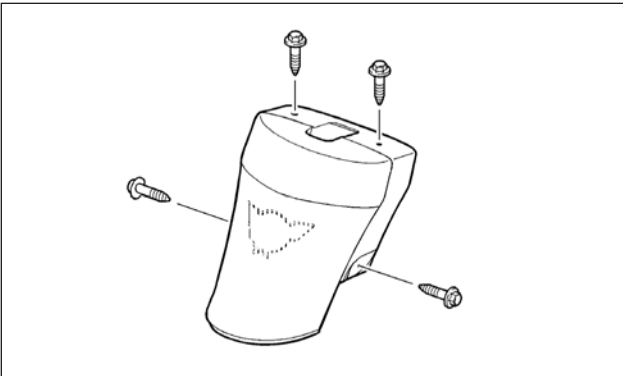

34. CONVERTIBLES ONLY: Reinstall the “waterfall” panel.

Congratulations, your B&M Precision Sportshifter™ is now installed and ready to enjoy!

2005-2007 (EARLY C6) MODELS

REMOVE THE STOCK SHIFTER

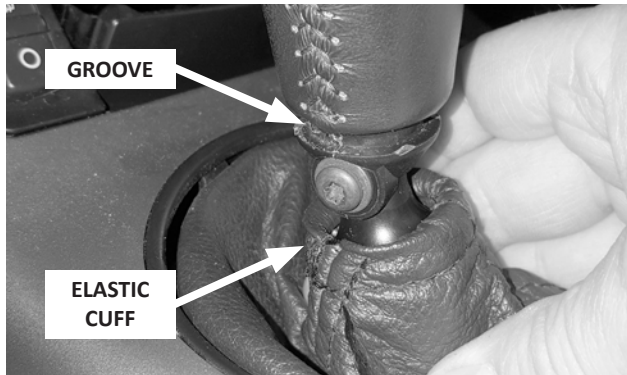

35. Separate the leather boot from the shift knob by working the boot's elastic cuff out of its groove, and pushing it down to expose the screw.

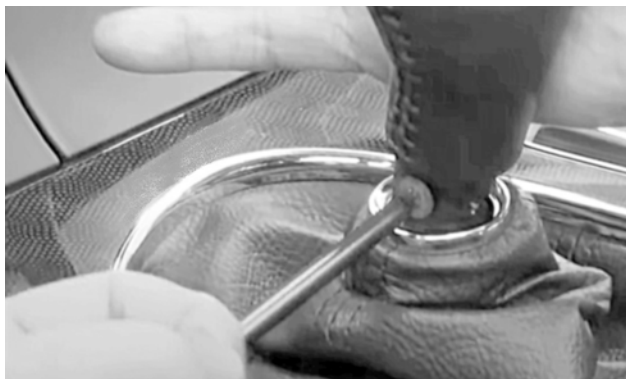

36. Remove the shift knob screw, then lift the knob off of the shift lever.

CAUTION: Avoid damaging the screw. Push firmly against the right side of the knob, and keep the screwdriver firmly inserted during removal.

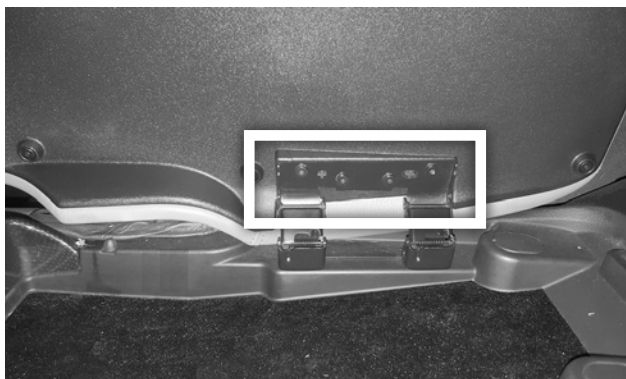

37. Open the center console lid, remove the 4 hinge screws, remove the lid, and close the hinge.

CAUTION: Avoid damaging the screw holes. Support the door while removing the last 2 screws.



38. At the front edge of the storage compartment, lift up on the rear edge of the half-round panel to detach it from the front console. Disconnect any electrical plugs, and set the panel aside.

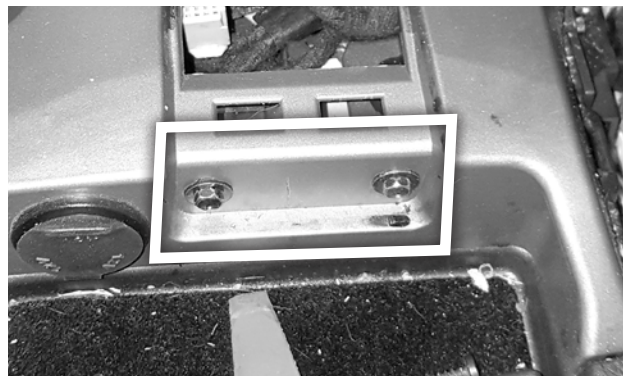

39. At the front of the storage compartment, remove the 2 screws next to the 12v receptacle.



40. On the left side of the parking brake, feel down through the boot, and separate the 2 friction clips from the console base. Then on the right side of the boot, release the 2 plastic tabs. Move the boot aside, and remove the 2 trim panel screws.

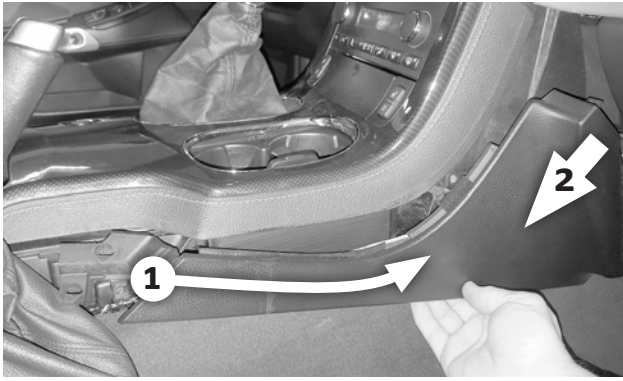

41. Starting at the rear of the right side trim panel and moving forward, gently work it out from between the carpet and the console. After freeing about half of the panel (to just past the curve), pull it down at a rearward angle to release 2 friction clips at the front, then set the panel aside.



42. Put the shifter in 4th gear and lift the boot opening off the end of the shift lever (to prevent it from catching). Starting at the rear of the front console and working forward, detach it from the console base and dash. Lift up on the rear edges first, then gently pull back on the front edges, just until all the friction clips have been released.

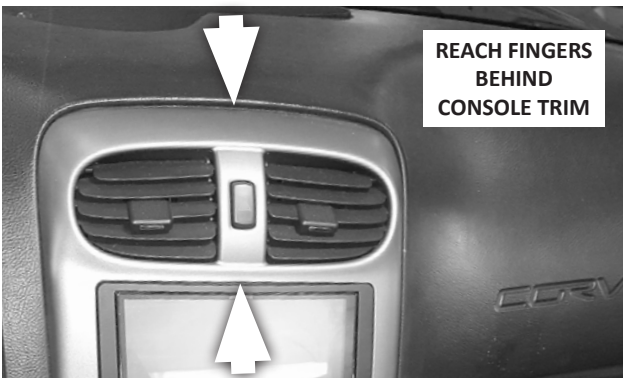

43. At the hazard light button, reach your fingers behind the front console from the top and bottom. Support the top of the hazard light plug with one hand, release the locking tab on the bottom of the plug with the other, and disconnect the plug from the switch.

- 44. Disconnect the heated seat plugs (if applicable). The locking tabs are on the bottom of each plug.
- 45. Disconnect the cigarette lighter plug (at the front of the console, behind the ash tray).

NOTE: The plug at the rear 12v receptacle (at the front of the console storage compartment) may remain connected.

- 46. Carefully move the front console cover around the parking brake handle and set it on the passenger seat.

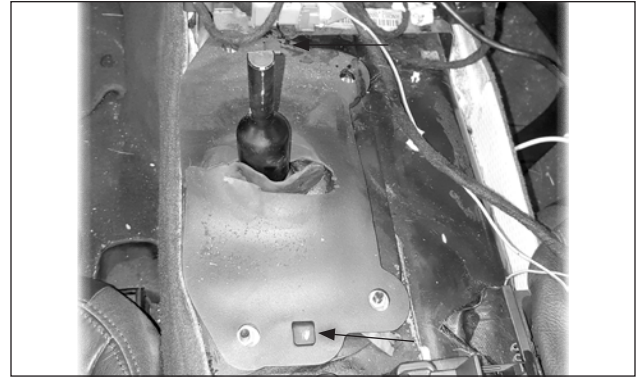

- 47. Release the sound insulation from its 2 tabs, lift it over the shift lever, and set it aside.



- 48. Remove the 4 nuts and the rubber dust boot and set them aside.

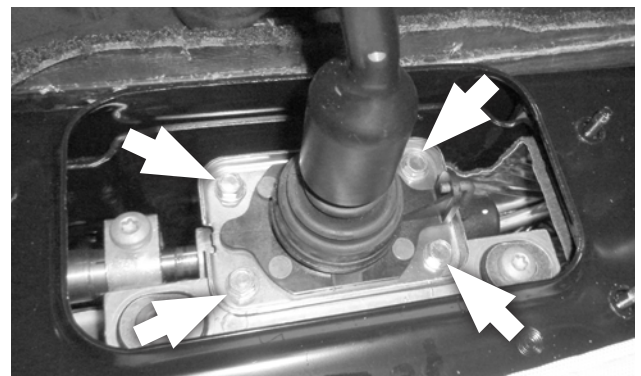

- 49. Put the shifter in Neutral. Then remove the 4 mount bolts and the shifter assembly, and remove any gasket material from the mount pad.

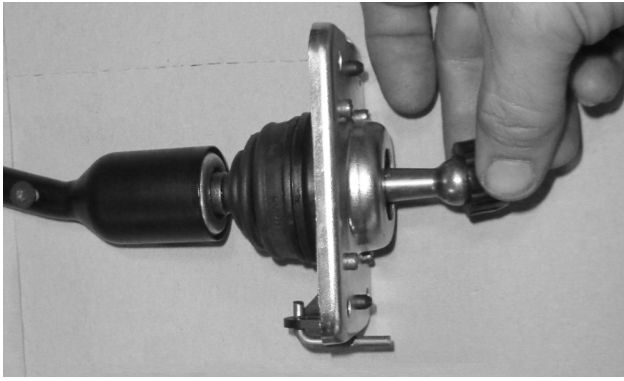

50. Remove the plastic pivot cup from the shift lever.

CAUTION: The pivot cup will be re-used. It should snap off by hand, but if you use pliers, take care not to damage it.

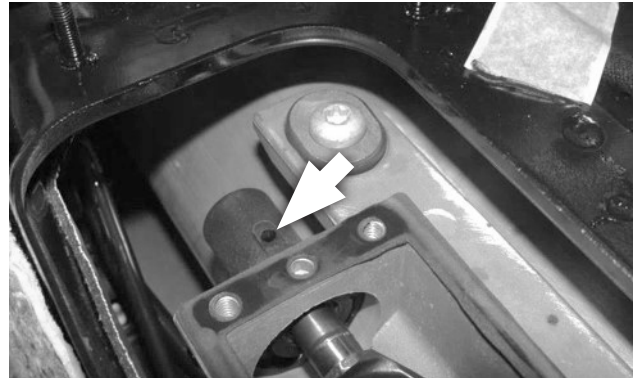

52. Insert the "L" pin FULLY into the hole in the shift linkage support in front of the shift box.

CAUTION: Full insertion is required to maintain shift linkage alignment while replacing the bushings.

OPTIONAL: REPLACE RUBBER STOCK BUSHINGS

This section (**Steps 51-56**) describes the replacement of the rubber stock bushings with the optional metal bushings included in this kit. (This does not apply to the Z06, which already uses metal bushings.)

Use of the metal bushings provides a more solid-feeling shift. However, it also transmits more noise and vibration to the passenger compartment. If a quieter, smoother shift is preferred, skip this section and proceed to **Step 57**.

NOTE: Handle all hardware with care to prevent it from falling into the shifter cavity.



53. Remove the two screws that secure the shift box to the vehicle.

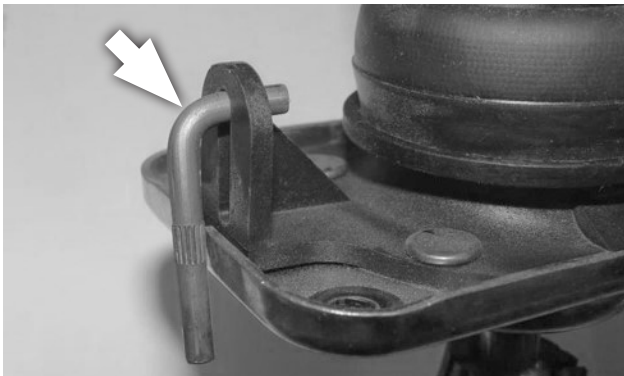

51. Remove the L-shaped alignment pin from the front of the stock shifter.



54. Remove the metal spacers and rubber bushings from both holes.

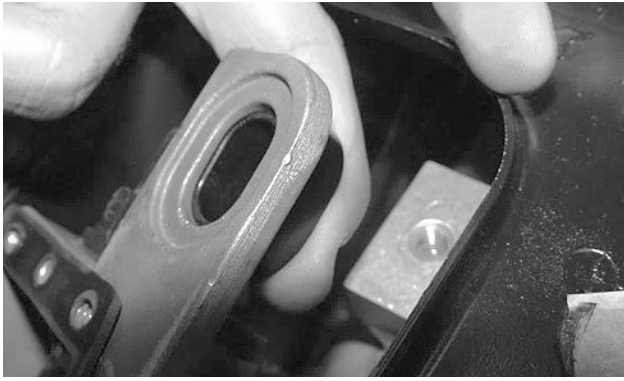

55. Lift the right side of shift box slightly, insert the kit's 2 metal bushings into the holes from the underside, then return the box to its normal position.



58. Install the new gasket on the mount pad on the shift box.



56. Apply medium-strength thread locker to the stock screws and reinstall them, along with the kit's 4 washers (2 per screw). After tightening both screws, remove the "L" pin.

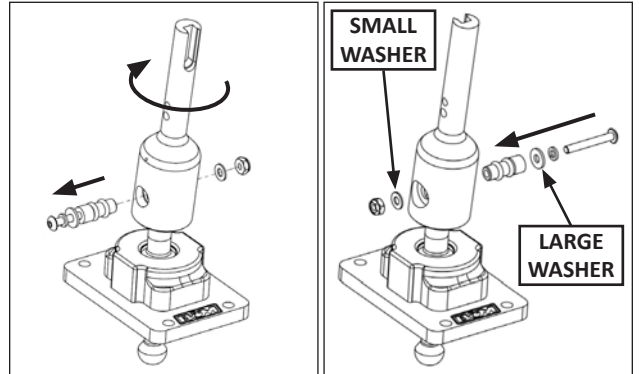

59. **Modify the shifter as follows:** First, loosen and remove the fasteners, washers and isolation insert that secure the top and bottom levers. Then rotate the top lever 180 degrees, aligning its holes with the hole in the bottom lever. Finally, reinstall the insert and fasteners as shown.

NOTE: The small O.D. washer goes under the nut, and the large O.D. and split lock-washers go under the screw head.

INSTALL THE B&M PRECISION SPORTSHIFTER

CAUTION: To avoid cracking the plastics during reassembly of the vehicle interior, do not over-tighten the screws.

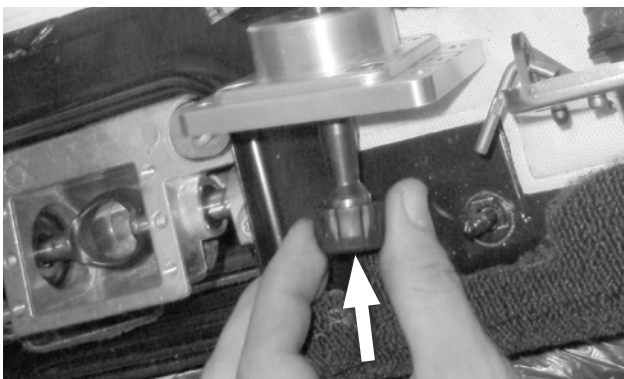

57. Grease the pivot ball at the bottom of the B&M shifter's lever. Then snap the stock pivot cup onto the pivot ball.

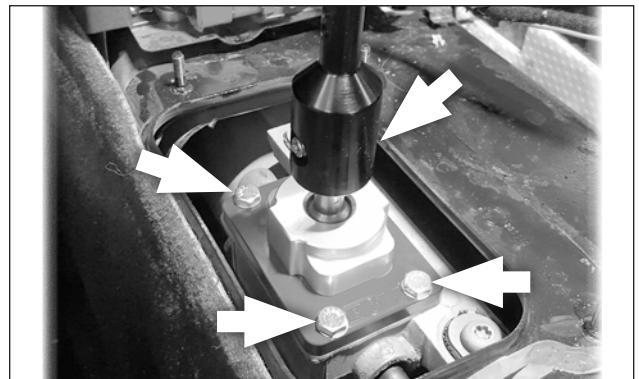

60. Place the shifter on the shift box, inserting the pivot cup into the shift linkage.

NOTE: Place the B&M logo toward the back, so that the shift lever is correctly tilted rearward.

Apply medium-strength thread locker to the four 1/4-20 screws, and secure the shifter to the shift box with the screws and 1/4" washers.

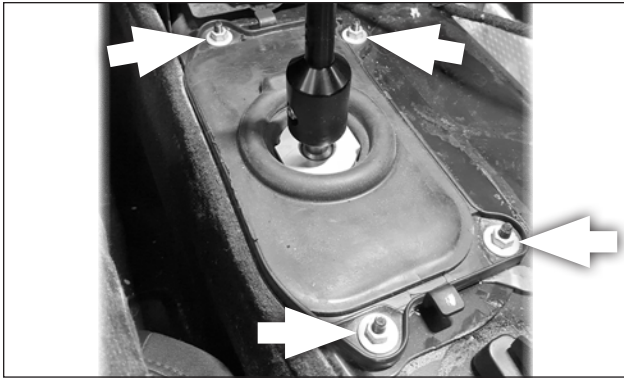

61. Reinstall the rubber dust boot using the 4 stock nuts.

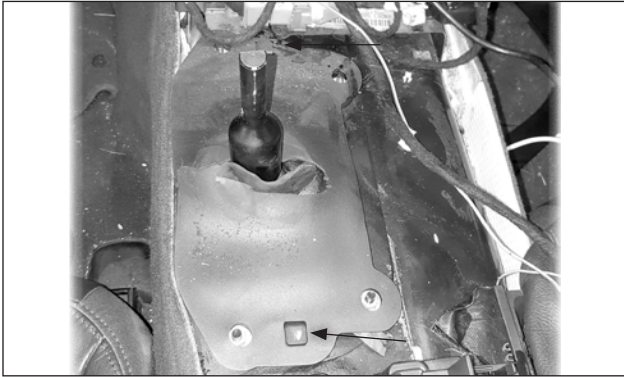

62. Reinstall the sound insulator, pushing its slots down over the tabs on the dust boot.

63. Move the front console close to the dash and console base.

64. Reconnect the cigarette lighter plug, the heated seat plugs (if applicable), and the hazard light button, and check the security of the connections.

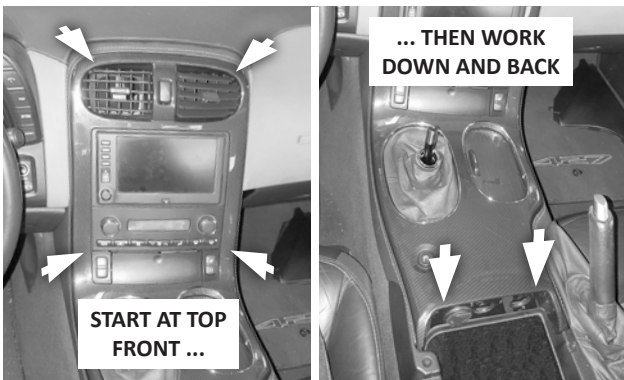

65. Starting at the front of the front console and working down and rearward, reattach it to the dash and console base.

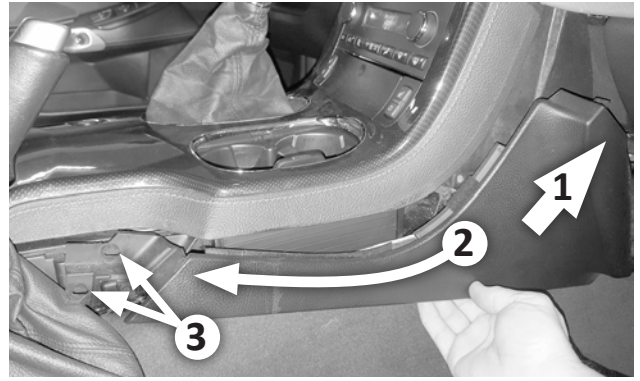

66. Reinstall the right side trim panel. First reattach the 2 front friction clips, then gently work it back in between the carpet and the console base. Finally, reinstall the 2 screws at the rear of the trim panel.



67. Reinstall the parking brake boot. First install the 2 plastic tabs on the right side of the boot, then reattach the 2 friction clips on the left side to the console base.

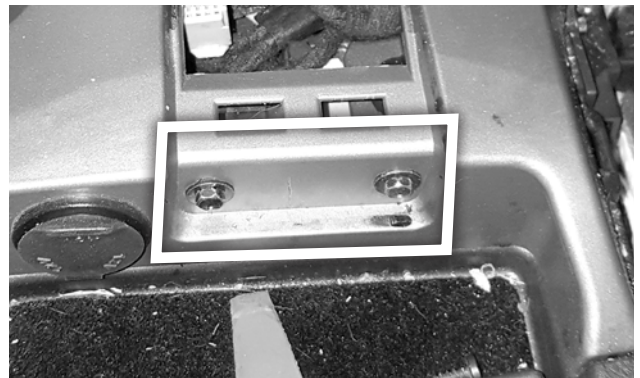

68. Reinstall the 2 screws at the front edge of the storage compartment (next to the 12v receptacle).

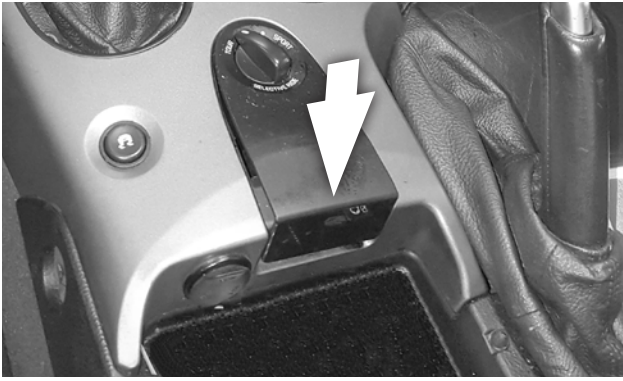

69. Reconnect any electrical plugs to the half-round panel, then reattach the panel to the front console.



72. Work the boot's elastic cuff back into the groove on the knob.

Congratulations, your B&M Precision Sportshifter™ is now installed and ready to enjoy!

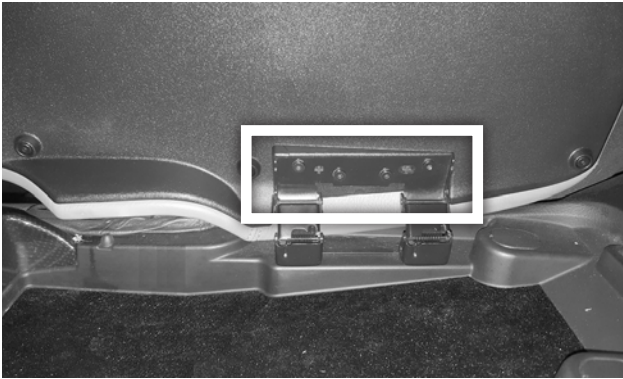

70. Reinstall the center console lid. Support the door with one hand while installing the 4 hinge screws.

CAUTION: Avoid damaging the screw holes. Do not over-tighten the screws.

Verify that the door latches shut when closed. (Loosen the screws and adjust cover alignment, if necessary.)

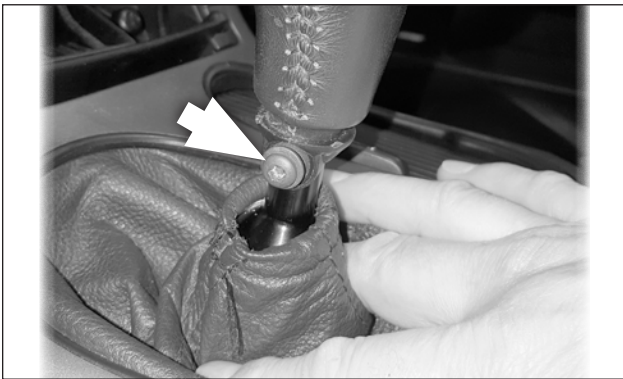

71. Place the knob on the shift lever. Apply medium-strength thread locker to the 6mm screw, and secure the knob to the lever.

KEEP THESE INSTRUCTIONS FOR FUTURE REFERENCE

B&M Performance maintains a highly-trained technical service department to answer your technical questions, provide additional product information and offer various recommendations.

B&M TECHNICAL SUPPORT: (866) 464-6553

